

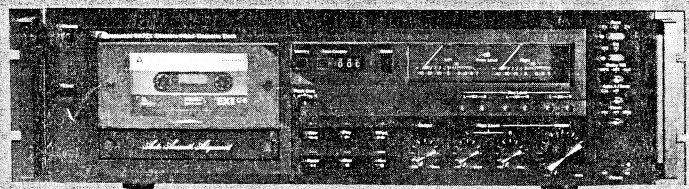

# Service Manual

# Nakamichi 660ZX

Discrete Head Cassette Deck



69

## CONTENTS

<b>1. General</b> .....	<b>3</b>
<b>2. Removal Procedures</b> .....	<b>5</b>
2. 1. Side Panel Ass'y .....	5
2. 2. Top Cover Ass'y .....	5
2. 3. Bottom Cover Ass'y .....	5
2. 4. Cassette Case Cover Ass'y and Azimuth Alignment Cover Ass'y .....	5
2. 5. Front Panel Ass'y .....	5
2. 6. Headphone Jack Ass'y .....	5
2. 7. Mechanism Ass'y .....	5
2. 8. Level Meter .....	6
2. 9. Auto Azimuth P.C.B. Ass'y .....	6
2. 10. Logic P.C.B. Ass'y .....	6
2. 11. Switch P.C.B. Ass'y .....	6
2. 12. Main P.C.B. Ass'y .....	6
2. 13. Volume P.C.B. Ass'y .....	6
2. 14. Record Cal. P.C.B. Ass'y .....	6
2. 15. Power Switch .....	6
2. 16. Lamp P.C.B. B Ass'y and Lamp P.C.B. C Ass'y .....	6
2. 17. Control Switch P.C.B. Ass'y .....	7
2. 18. RAMM P.C.B. Ass'y .....	7
2. 19. Rear Panel Ass'y .....	7
2. 20. Power Transformer and Fuse P.C.B. Ass'y .....	7
2. 21. Cassette Case Ass'y and Cover Plate Ass'y .....	7
2. 22. Tape Counter Ass'y, Memory Switch and Pitch Control Volume .....	7
2. 23. Capstan Motor Ass'y and Flywheel Ass'y .....	7
2. 24. Sub Mechanism Chassis Ass'y .....	7
2. 25. Control Motor Ass'y and Reel Motor Ass'y .....	7
2. 26. Cam Control Volume .....	8
2. 27. Azimuth Motor Ass'y .....	8
2. 28. Reel Hub Ass'y and Idler Ass'y .....	8
2. 29. Cam Drive Gear and Control Cam .....	8
2. 30. Head Mount Base Ass'y .....	9
2. 31. Pressure Roller Ass'y and Erase Head .....	9
2. 32. Playback Head Ass'y and Record Head Ass'y .....	9
<b>3. Measurement Instruments</b> .....	<b>10</b>
<b>4. Mechanical Adjustments</b> .....	<b>11</b>
4. 1. Mechanism Control Cam Adjustment .....	11
4. 2. Tape Speed Adjustment .....	12
4. 3. Record Head and Playback Head Tilt Adjustment .....	13
4. 4. Head Base Stroke Adjustment in Play and Cue Modes .....	14
4. 5. Tape Guides Adjustment and Erase Head Stroke Adjustment .....	15
4. 6. Erase Head Height and Tilt Adjustment .....	15
4. 7. Back Tension Adjustment .....	16
4. 8. Playback Head and Record Head Height Adjustment and Azimuth Alignment .....	18
4. 9. Record Head Stroke Adjustment .....	19
4. 10. Tape Travelling Adjustment .....	20
4. 11. Record Switch Linkage Adjustment .....	20
4. 11. Flywheel Holder Adjustment .....	20
4. 12. Lubrication .....	20
<b>5. Parts Location for Electrical Adjustment</b> .....	<b>21</b>
<b>6. Electrical Adjustments and Measurements</b> .....	<b>22</b>
6. 1. Adjustment and Measurement Instructions .....	22
6. 2. Frequency Response Adjustment .....	27
6. 3. Dolby NR Circuit Check .....	28
<b>7. Mounting Diagrams</b> .....	<b>28</b>
7. 1. Control Switch P.C.B. Ass'y .....	28

7. 2.	Lamp P.C.B. B Ass'y	28
7. 3.	Lamp P.C.B. C Ass'y	28
7. 4.	RAMM P.C.B. Ass'y	28
7. 5.	Fuse P.C.B. Ass'y	29
7. 6.	Auto Azimuth P.C.B. Ass'y	30
7. 7.	Pin Jack P.C.B. Ass'y	30
7. 8.	Auto Shut-off P.C.B. Ass'y	30
7. 9.	Switch P.C.B. Ass'y	31
7. 10.	Record Cal. P.C.B. Ass'y	31
7. 11.	Volume P.C.B. Ass'y	31
7. 12.	Main P.C.B. Ass'y	33
7. 13.	Logic P.C.B. Ass'y	35
<b>8.</b>	<b>Mechanism Ass'y and Parts List</b>	<b>37</b>
8. 1.	Synthesis	37
8. 2.	Front Panel Ass'y (A01)	40
8. 3.	Mechanism Ass'y 660ZX (A02)	41
8. 4.	Chassis Ass'y (A03)	44
8. 5.	Front Panel Escutcheon Ass'y (B01)	44
8. 6.	Control Button Ass'y (B02)	44
8. 7.	Flywheel Holder Ass'y (C01)	44
8. 8.	Sub Mechanism Chassis Ass'y (C02)	45
8. 9.	Main Mechanism Chassis Ass'y (C03)	48
8. 10.	Record Calibration Ass'y (D01)	53
8. 11.	Volume Holder Ass'y (D02)	53
8. 12.	Headphone Jack Ass'y (D03)	53
8. 13.	Reflector Ass'y (D04)	53
8. 14.	Counter Lamp Ass'y (D05)	53
8. 15.	Power Switch Holder Ass'y (D06)	53
8. 16.	Rear Panel Ass'y (D07)	54
8. 17.	Reel Motor Ass'y (E01)	56
8. 18.	Control Motor Ass'y (E02)	56
8. 19.	Azimuth Alignment Motor Ass'y (E03)	56
8. 20.	Head Mount Base Ass'y (F01)	56
8. 21.	Supply Pressure Roller Ass'y (F02)	56
8. 22.	Take-up Pressure Roller Ass'y (F03)	56
8. 23.	Head Base Ass'y D (F04)	56
8. 24.	Cassette Case Holder L Ass'y (F05)	56
8. 25.	Cassette Case Holder R Ass'y (F06)	56
8. 26.	Auto Shut-off Ass'y (F07)	57
8. 27.	Pneumatic Damper Ass'y (F08)	57
8. 28.	Pitch Control Holder Ass'y (F09)	57
8. 29.	Azimuth Motor Ass'y (G01)	57
8. 30.	P-8L Playback Head Ass'y (H01)	57
8. 31.	R-8L Record Head Ass'y (H02)	57
<b>9.</b>	<b>Overall Timing Chart</b>	<b>58</b>
<b>10.</b>	<b>Eq. Amp. Frequency Response</b>	<b>58</b>
10. 1.	Playback Frequency Response	58
10. 2.	Record Current Frequency Response	58
<b>11.</b>	<b>Block Diagrams</b>	<b>59</b>
11. 1.	Amplifier	59
11. 2.	Mechanism Control	60
<b>12.</b>	<b>Wiring Diagram</b>	<b>61</b>
<b>13.</b>	<b>Schematic Diagrams</b>	<b>63</b>
13. 1.	Amplifier	63
13. 2.	Mechanism Control	64
<b>14.</b>	<b>Specifications</b>	<b>65</b>

# 660ZX

## 1.1. Control Functions

Nakamichi 660ZX control functions are shown below:

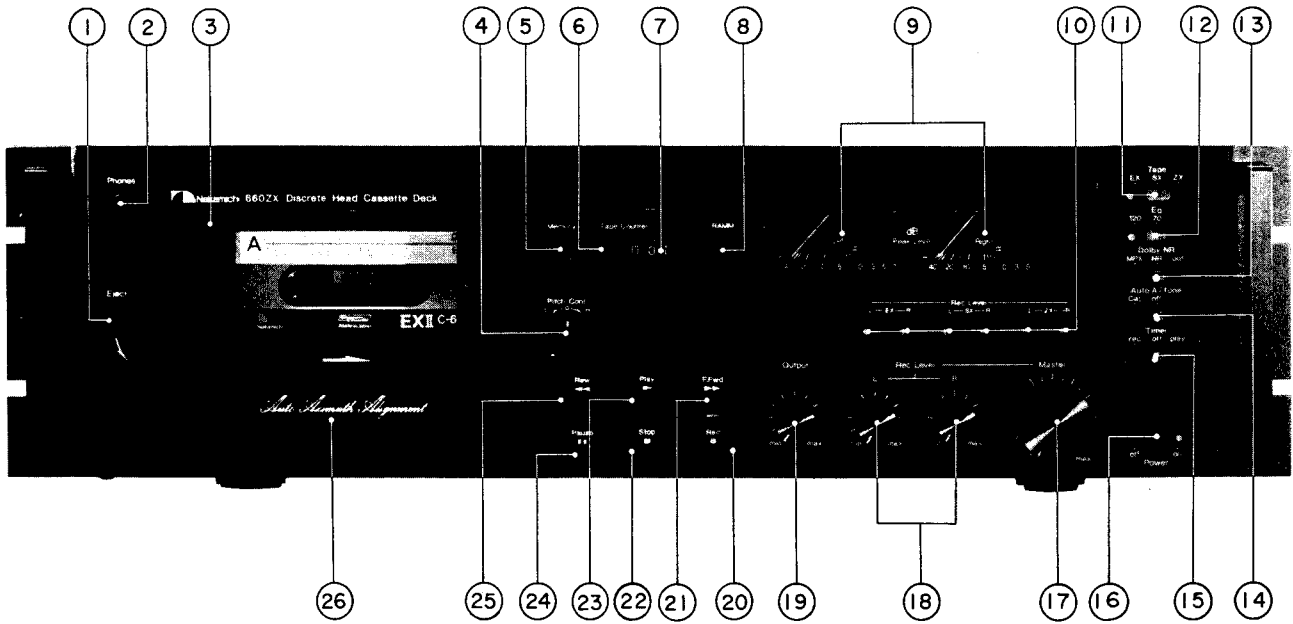

Fig. 1.1 Front View

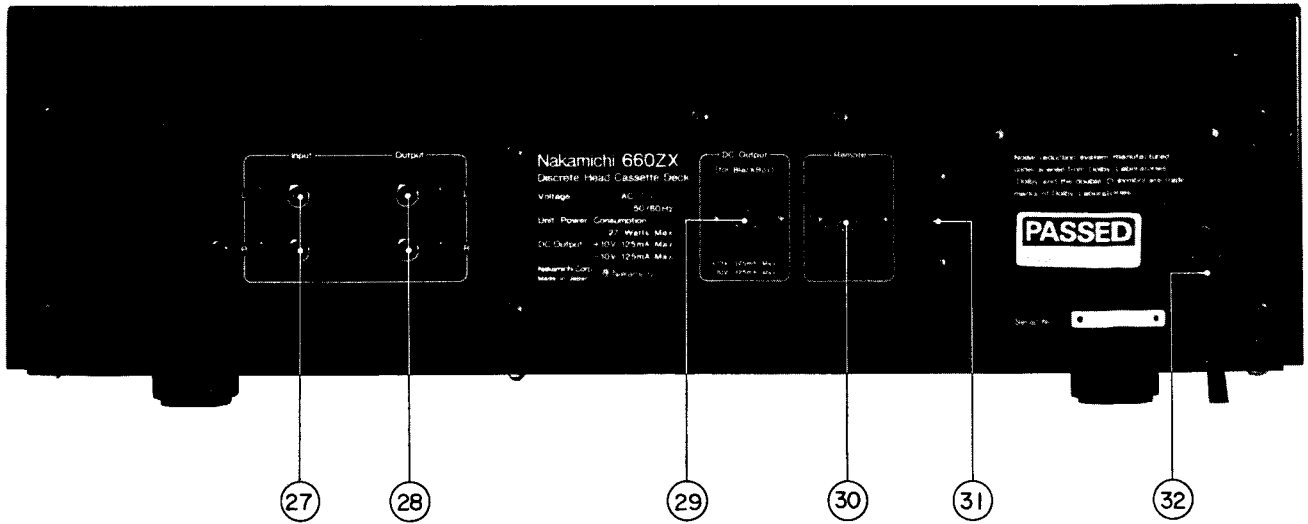

Fig. 1.2 Rear View

1. Eject Lever
2. Headphone Jack
3. Cassette Holder (with see-thru cover)
4. Pitch Control
5. Tape Start Memory Switch
6. Counter Reset Button
7. Tape Counter
8. RAMM Display
9. Peak Level Meters
10. Record Calibration Controls
11. Tape Switch (EX/SX/ZX)
12. Eq. Switch (120  $\mu$ s/70  $\mu$ s)
13. Dolby NR/MPX Filter Switch
14. Auto. A/Tone Switch
15. Timer Switch
16. Power Switch
17. Master Input Level Control
18. Input Level Controls
19. Output Level Control
20. Record Button
21. Fast-Forward Button
22. Stop Button
23. Play Button
24. Pause Button
25. Rewind Button
26. Auto Azimuth Alignment Cover
27. Input Jacks
28. Output Jacks
29. DC Output Jack
30. Remote Control Socket
31. Voltage Selector
32. Power Cord

### **1.2. Voltage Selector**

Voltage selector is installed on the rear panel for other versions of the Nakamichi 660ZX. This voltage selector can select either 120 V or 220 – 240 V at customer's disposal.

## 2. REMOVAL PROCEDURES

### 2.1. Side Panel Ass'y

Refer to Fig. 2.1.

Remove F01 and F02, then disassemble F03 (Side Panel Ass'y).

### 2.2. Top Cover Ass'y

Refer to Fig. 2.1.

(1) Remove Side Panel Ass'y referring to item 2.1.

(2) Remove F04 and F05, then disassemble F06 (Top Cover Ass'y).

### 2.3. Bottom Cover Ass'y

Refer to Fig. 2.1.

Remove F07, then disassemble F08 (Bottom Cover Ass'y).

### 2.4. Cassette Case Cover Ass'y and Azimuth Alignment Cover Ass'y

Refer to Fig. 2.1.

(1) Turn fully counterclockwise two screws which are mounted on the Cassette Case Cover, then disassemble F09 (Cassette Case Cover Ass'y).

(2) Turn fully counterclockwise two screws which are mounted on the Front Panel Escutcheon Ass'y, then disassemble F10 (Azimuth Alignment Cover Ass'y).

### 2.5. Front Panel Ass'y

Refer to Fig. 2.2.

(1) Refer to Fig. 2.1. Remove Top Cover Ass'y and Bottom Cover Ass'y referring to items 2.2 and 2.3.

(2) Pull out F01 (Volume Knob A), F02 (Volume Knob B) and F03 (Pitch Control Knob).

(3) Remove F04, F05 and F06, then disassemble F07 (Front Panel Ass'y including 3 connectors).

### 2.6. Headphone Jack Ass'y

Refer to Fig. 2.2.

(1) Remove Front Panel Ass'y referring to item 2.5.

(2) Remove F08, then disassemble F09 (Headphone Jack Ass'y).

### 2.7. Mechanism Ass'y

Refer to Fig. 2.2.

(1) Remove Front Panel Ass'y referring to item 2.5.

(2) Remove F10, then disassemble F11 (Mechanism Ass'y including 7 connectors).

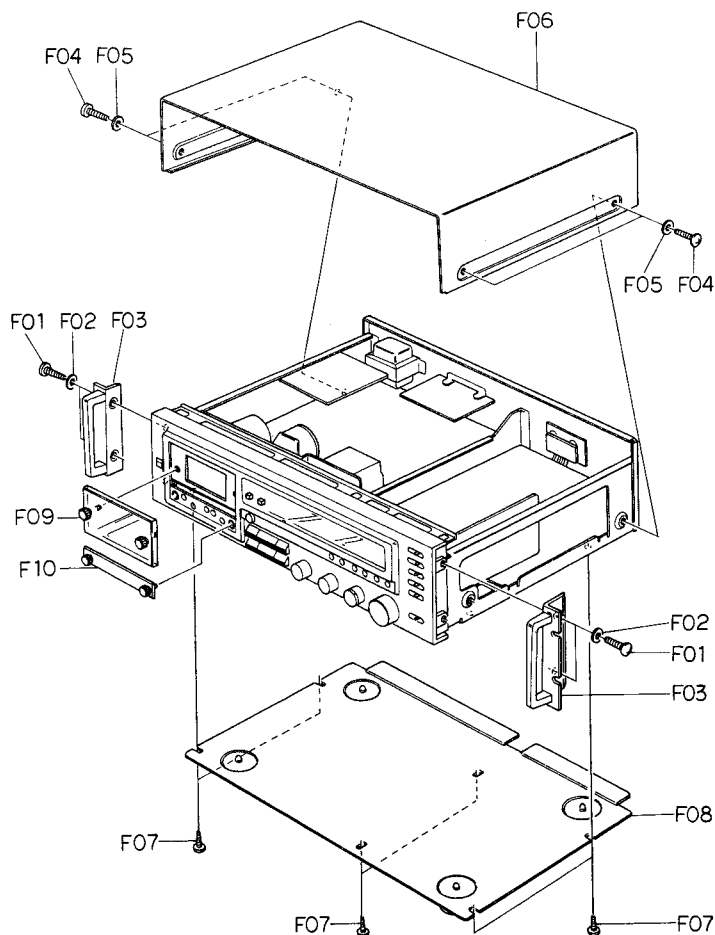

Fig. 2.1

**2.8. Level Meter**

Refer to Fig. 2.3.

- (1) Refer to Fig. 2.2. Remove Front Panel Ass'y referring to item 2.5.
- (2) Remove F01, then disassemble F02 (Level Meter Holder) and F03 (Level Meter).

**2.9. Auto Azimuth P.C.B. Ass'y**

Refer to Fig. 2.3.

- (1) Refer to Fig. 2.2. Remove Front Panel Ass'y referring to item 2.5.
- (2) Remove one connector and the wires connected by wrapping.
- (3) Remove F04, then disassemble F05 (Auto Azimuth P.C.B. Ass'y).

**2.10. Logic P.C.B. Ass'y**

Refer to Fig. 2.3.

- (1) Refer to Fig. 2.2. Remove Front Panel Ass'y referring to item 2.5.
- (2) Remove 7 connectors and the wires connected by wrapping from F07 (Logic P.C.B. Ass'y).
- (3) Remove F06, then disassemble F07 (Logic P.C.B. Ass'y).

**2.11. Switch P.C.B. Ass'y**

Refer to Fig. 2.3.

- (1) Refer to Fig. 2.2. Remove Front Panel Ass'y referring to item 2.5.
- (2) Pull out F08 (Function Switch Knob Ass'y).
- (3) Remove the Flat Cables, connector and wires connected by wrapping from F11 (Switch P.C.B. Ass'y).
- (4) Remove F09 and F10, then disassemble F11 (Switch P.C.B. Ass'y).

**2.12. Main P.C.B. Ass'y**

Refer to Fig. 2.3.

- (1) Remove Level Meter and Switch P.C.B. Ass'y referring to items 2.8 and 2.11.
- (2) Remove the Flat Cables, 3 connectors and wires connected by wrapping from F13 (Main P.C.B. Ass'y).
- (3) Remove F12, then disassemble F13 (Main P.C.B. Ass'y).

**2.13. Volume P.C.B. Ass'y**

Refer to Fig. 2.3.

- (1) Remove Level Meter referring to item 2.8.
- (2) Remove F14 and the Flat Cable from F15 (Volume P.C.B. Ass'y), then disassemble F15 (Volume P.C.B. Ass'y).

**2.14. Record Cal. P.C.B. Ass'y**

Refer to Fig. 2.3.

- (1) Refer to Fig. 2.2. Remove Front Panel Ass'y referring to item 2.5.
- (2) Remove F16, then disassemble F17 (Calibration Case Ass'y).
- (3) Remove F18, then disassemble F19 (Record Cal. P.C.B. Ass'y).

**2.15. Power Switch**

Refer to Fig. 2.3.

- (1) Refer to Fig. 2.2. Remove Front Panel Ass'y referring to item 2.5.
- (2) Remove F20, then disassemble F21 (Power Switch Knob).
- (3) Remove F22, then disassemble F23 (Power Switch Holder Ass'y).
- (4) Remove F24, then disassemble F25 (Power Switch).

**2.16. Lamp P.C.B. B Ass'y and Lamp P.C.B. C Ass'y**  
Refer to Fig. 2.3.

- (1) Refer to Fig. 2.2. Remove Front Panel Ass'y referring to item 2.5.
- (2) Remove F26, then disassemble F27 (Insulator) and F28 (Lamp P.C.B. B Ass'y).
- (3) Remove F29 (Lamp P.C.B. C Ass'y) by releasing the self-interlocking pin of the Reflector.

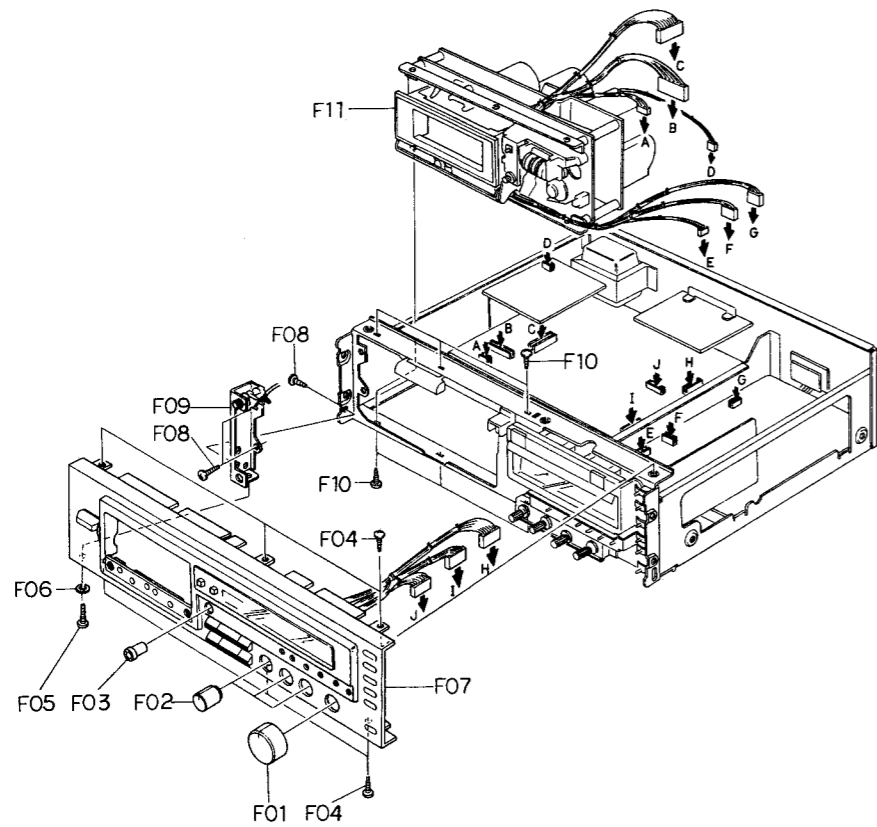

Fig. 2.2

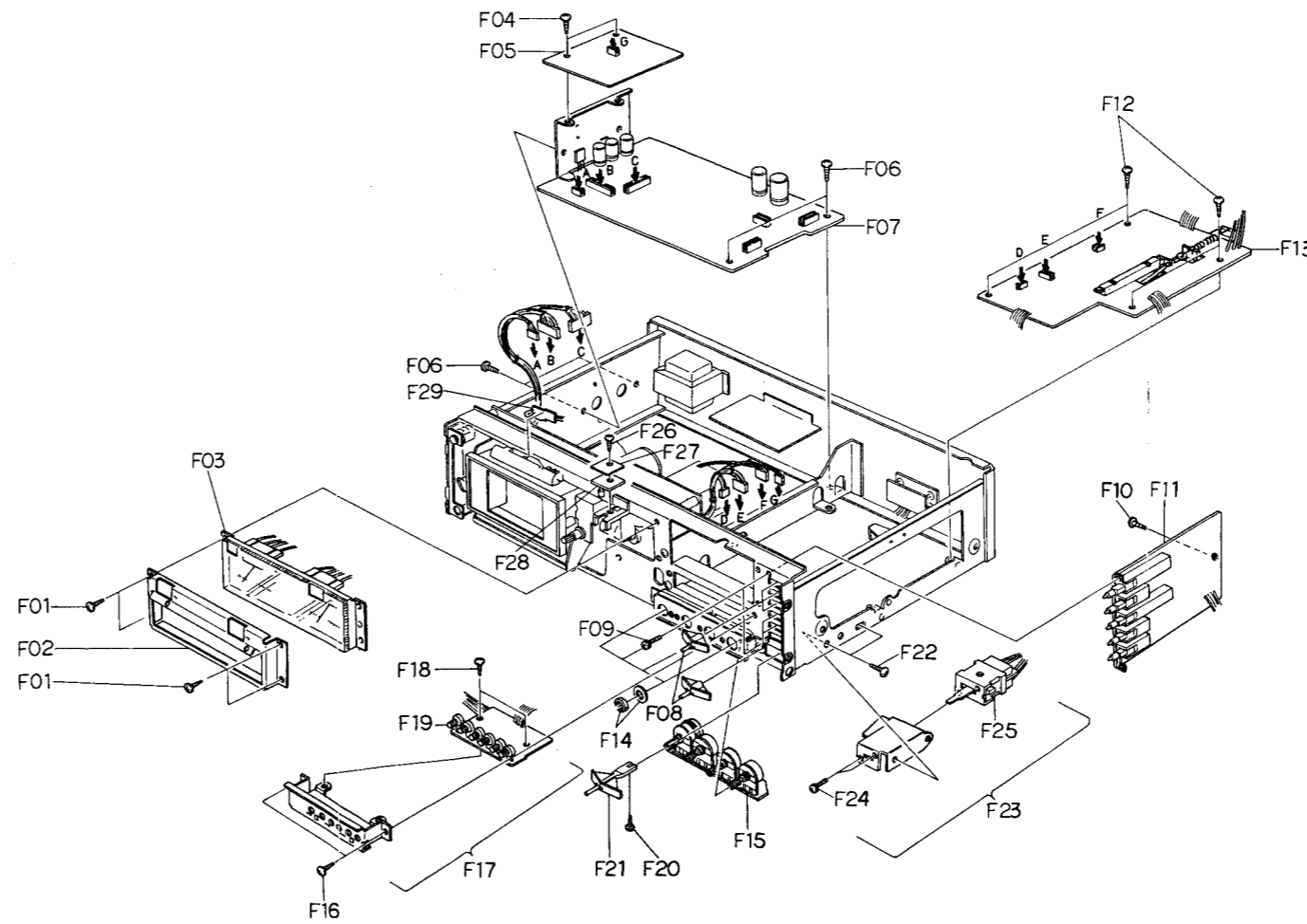

Fig. 2.3

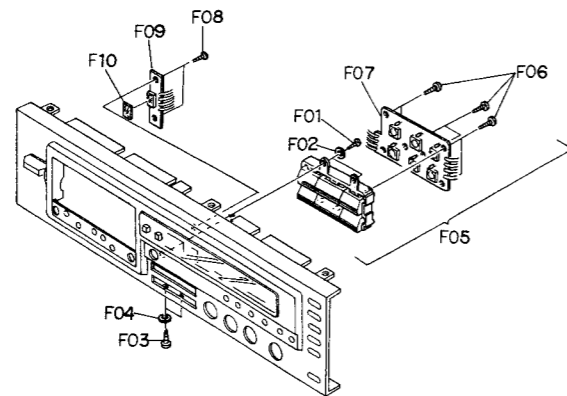

Fig. 2.4

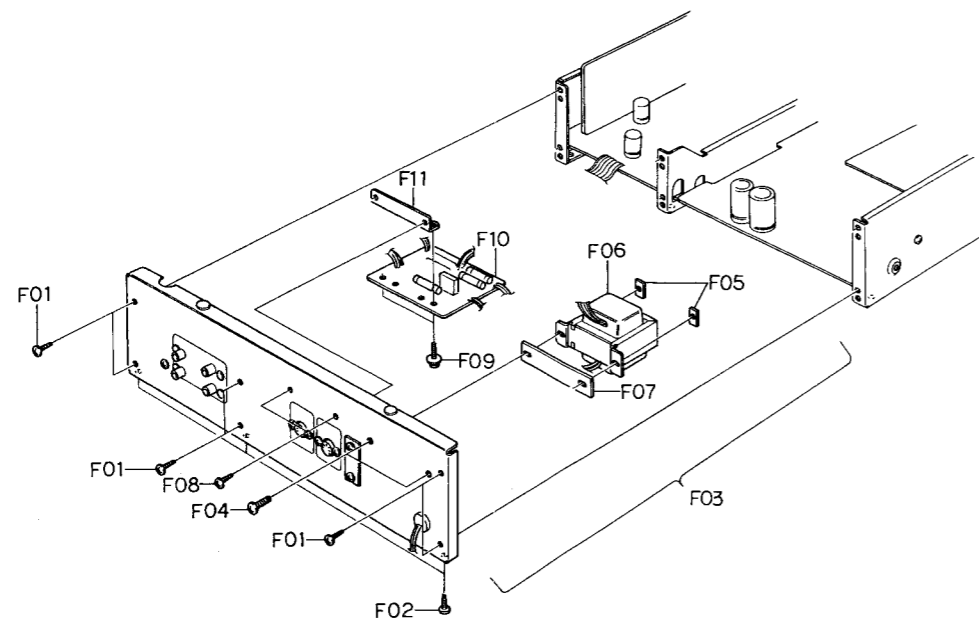

Fig. 2.5

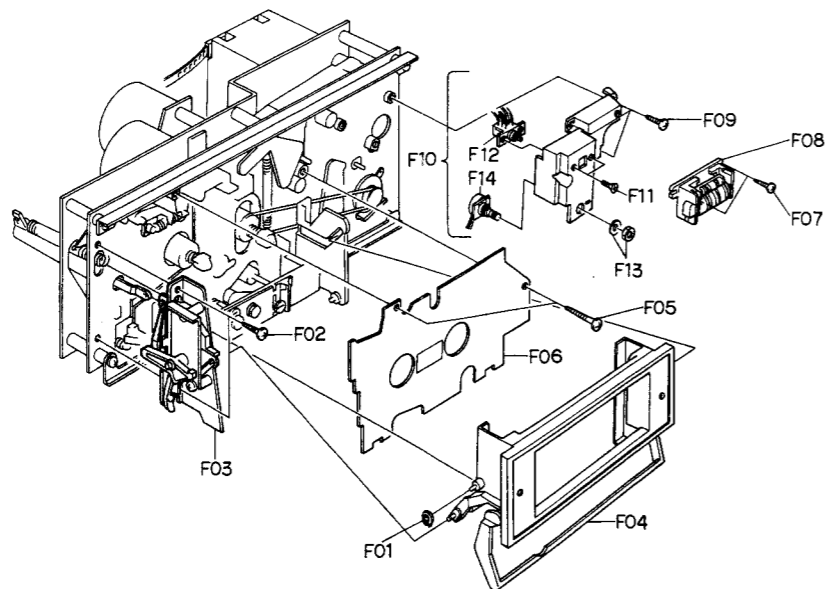

Fig. 2.6

**2.17. Control Switch P.C.B. Ass'y**

Refer to Fig. 2.4.

- (1) Refer to Fig. 2.2. Remove Front Panel Ass'y referring to item 2.5.
- (2) Remove F01, F02, F03 and F04, then disassemble F05 (Control Button Ass'y).
- (3) Remove F06, then disassemble F07 (Control Switch P.C.B. Ass'y).

**2.18. RAMM P.C.B. Ass'y**

Refer to Fig. 2.4.

- (1) Refer to Fig. 2.2. Remove Front Panel Ass'y referring to item 2.5.
- (2) Remove F08, then disassemble F09 (RAMM P.C.B. Ass'y) and F10 (LED Filter).

**2.19. Rear Panel Ass'y**

Refer to Fig. 2.5.

- (1) Refer to Fig. 2.1. Remove Top Cover Ass'y and Bottom Cover Ass'y referring to items 2.2 and 2.3.
- (2) Remove F01 and F02, then disassemble F03 (Rear Panel Ass'y).

**2.20. Power Transformer and Fuse P.C.B. Ass'y**

Refer to Fig. 2.5.

- (1) Refer to Fig. 2.1. Remove Top Cover Ass'y and Bottom Cover Ass'y referring to items 2.2 and 2.3.
- (2) Remove F04 and F05, then disassemble F06 (Power Transformer) and F07 (Transformer Plate).
- (3) Remove F08 and F09, then disassemble F10 (Fuse P.C.B. Ass'y).

**2.21. Cassette Case Ass'y and Cover Plate Ass'y**

Refer to Fig. 2.6.

- (1) Refer to Fig. 2.2. Remove Mechanism Ass'y referring to item 2.7.
- (2) Press the Eject Button to open the Cassette Case Ass'y.
- (3) Remove F01 and F02, then disassemble F03 (Cassette Case Holder L Ass'y) by releasing the self-interlocking pin of the Damper Lock Arm and F04 (Cassette Case Ass'y).
- (4) Remove F05, then disassemble F06 (Cover Plate Ass'y).

**2.22. Tape Counter Ass'y, Memory Switch and Pitch Control Volume**

Refer to Fig. 2.6.

- (1) Refer to Fig. 2.2. Remove Mechanism Ass'y referring to item 2.7.
- (2) Remove F07, then disassemble F08 (Tape Counter Ass'y).
- (3) Remove F09, then disassemble F10 (Pitch Control Holder Ass'y).
- (4) Remove F11, then disassemble F12 (Memory Switch).
- (5) Remove F13, then disassemble F14 (Pitch Control Volume).

**2.23. Capstan Motor Ass'y and Flywheel Ass'y**

Refer to Fig. 2.7.

- (1) Refer to Fig. 2.2. Remove Mechanism Ass'y referring to item 2.7.
- (2) Remove F01 and F02, then disassemble F03 (Flywheel Holder Ass'y) and F08 (Capstan Belt).
- (3) Remove F04, then disassemble F05 (Capstan Motor Ass'y).
- (4) Remove F06, then disassemble F07 (Speed Cal. P.C.B. Ass'y).
- (5) Remove F09 (Supply Flywheel Ass'y), then disassemble F10 (Take-up Flywheel Ass'y).
- (6) After removing both Flywheel Assemblies, disassemble F11 (Thrust Washer 3 mm), F12 (Thrust Washer 2.6 mm), F13 (Flange Thrust Cap) and F14 (Thrust Spring).

**2.24. Sub Mechanism Chassis Ass'y**

Refer to Fig. 2.8.

- (1) Remove Flywheel Holder Ass'y referring to item 2.23.
- (2) Remove F01 and F02, then disassemble F03 (Sub Mechanism Chassis Ass'y).

**2.25. Control Motor Ass'y and Reel Motor Ass'y**

Refer to Fig. 2.8.

- (1) Remove Sub Mechanism Chassis Ass'y referring to item 2.24.
- (2) Remove F04, then disassemble F05 (Control Motor Ass'y).
- (3) Remove F06, then disassemble F07 (Reel Motor Ass'y).



**2.26. Cam Control Volume**

Refer to Fig. 2.8.

- (1) Remove Sub Mechanism Chassis Ass'y referring to item 2.24.
- (2) Remove F08, then disassemble F09 (Volume Coupler).
- (3) Remove F10, then disassemble F11 (Cam Control Volume).

**2.27. Azimuth Motor Ass'y**

Refer to Fig. 2.8.

- (1) Remove Sub Mechanism Chassis Ass'y referring to item 2.24.
- (2) Remove F12, then disassemble F13 (Azimuth Alignment Motor Ass'y).
- (3) Remove F14, then disassemble F15 (Azimuth Motor Ass'y) and F16 (Drive Pulley Ass'y).

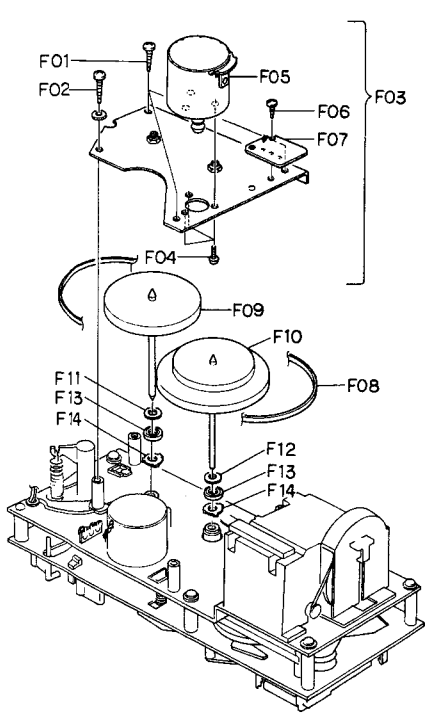

Fig. 2.7

**2.28. Reel Hub Ass'y and Idler Ass'y**

Refer to Fig. 2.8.

- (1) Remove Sub Mechanism Chassis Ass'y referring to item 2.24.
- (2) Remove F17 (Reel Hub Head), then disassemble F18 (Reel Hub B Ass'y), F19 (Reel Hub Take-up Ass'y), F20 (Reel Hub Supply Ass'y), F21 (Back Tension Ass'y) and F22 (Back Tension Spring).
- (3) Remove F23, then disassemble F24 (Idler Ass'y).

**2.29. Cam Drive Gear and Control Cam**

Refer to Fig. 2.8.

- (1) Remove Sub Mechanism Chassis Ass'y referring to item 2.24.
- (2) Remove F25, then disassemble F26 (Cam Drive Gear).
- (3) Remove F27, then disassemble F28 (Counter-Load Arm Ass'y).
- (4) Remove F29, then disassemble F30 (Control Cam).

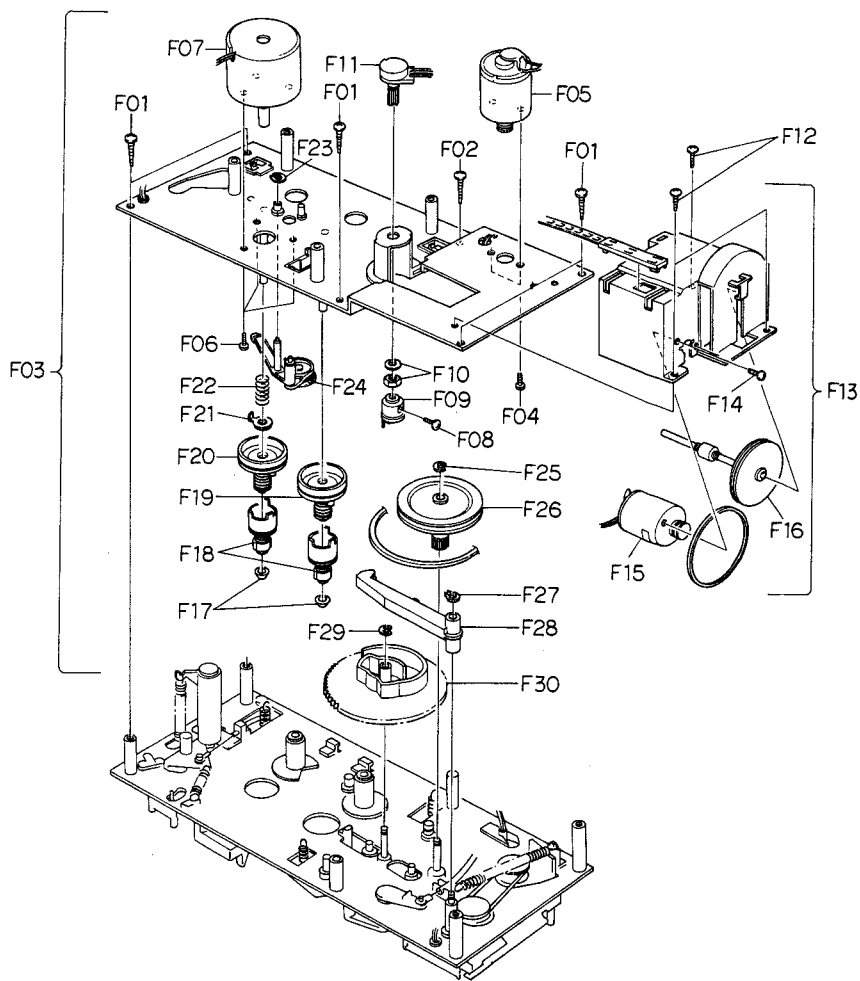

Fig. 2.8

**2.30. Head Mount Base Ass'y**

Refer to Fig. 2.9.

- (1) Refer to Fig. 2.6. Remove Cassette Case Ass'y referring to item 2.21.
- (2) Remove F01, then disassemble F02 (Head Mount Base Ass'y).

**2.31. Pressure Roller Ass'y and Erase Head**

Refer to Fig. 2.9.

- (1) Remove Head Mount Base Ass'y referring to item 2.30.
- (2) Remove F03, then disassemble F04 (Supply Pressure Roller Ass'y).
- (3) Remove F05, then disassemble F06 (Erase Head).
- (4) Remove F07, then disassemble F08 (Take-up Pressure Roller Ass'y).

**2.32. Playback Head Ass'y and Record Head Ass'y**

Refer to Fig. 2.9.

- (1) Remove Head Mount Base Ass'y referring to item 2.30.
- (2) Turn F09 by 90° by pushing it, then disassemble F10 (Playback Head Ass'y).
- (3) Turn F10 by 90° by pushing it, then disassemble F12 (Record Head Ass'y) and F13 (RH Azimuth Alignment Plate).

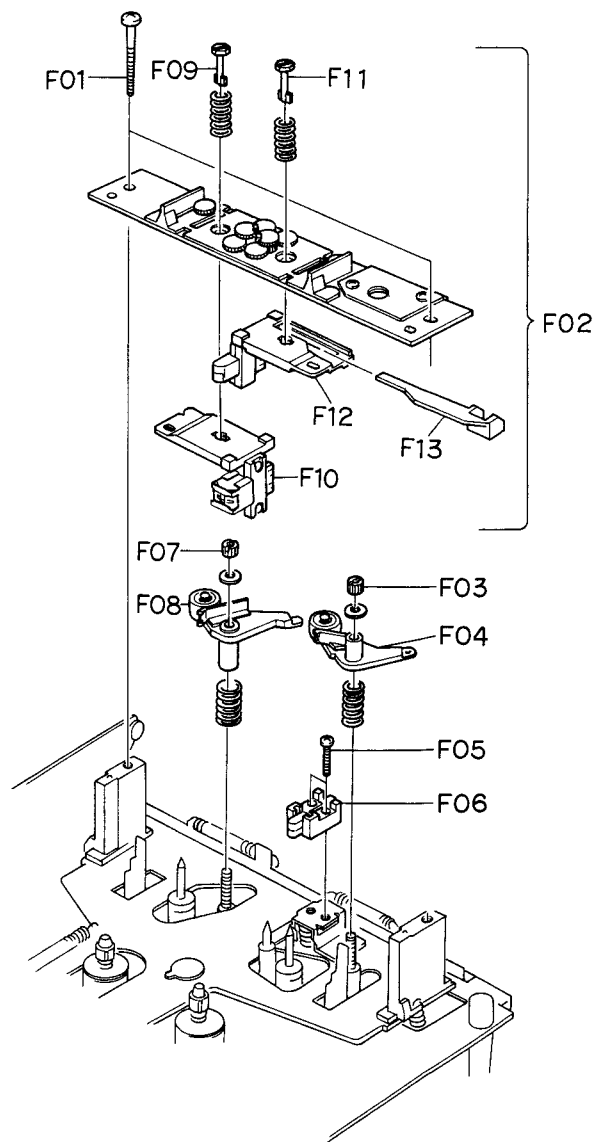

Fig. 2.9

### 3. MEASUREMENT INSTRUMENTS

- (1) Audio Generator (20 Hz – 200 kHz)
- (2) AC Millivolt Meter (with dB measures)
- (3) Oscilloscope (DC – 5 MHz)
- (4) Distortion Meter
- (5) Speed & Wow/Flutter Meter
- (6) Frequency Counter (DC – 1 MHz)
- (7) Ohm Meter
- (8) DC Volt Meter
- (9) AC Volt Meter
- (10) Torque Gauge (DA09013A)
- (11) 15 kHz Azimuth Tape (DA09004A)
- (12) 3 kHz Speed & Wow/Flutter Tape (DA09006A)
- (13) 1 kHz Track Alignment Tape (DA09007A)
- (14) 400 Hz Level Tape (DA09005A)
- (15) 20 kHz PB Frequency Response Tape (DA09001A)
- (16) 15 kHz PB Frequency Response Tape (DA09002A)
- (17) 10 kHz PB Frequency Response Tape (DA09003A)
- (18) Reference EXII Tape (DA09021A)
- (19) Reference SX Tape (DA09025A)
- (20) Reference ZX Tape (DA09037A)
- (21) Tilt Check Gauge M-9039 (DA09039A)
- (22) EH Tilt Check Gauge M-9040 (DA09040A)
- (23) EH Stroke Check Gauge M-9042 (DA09042A)
- (24) EH Stroke Check Gauge M-9051 (DA09051A)
- (25) Stroke Check Gauge M-9047 (DA09047A)
- (26) Record Head Mounting Gauge M-9048 (DA09048A)
- (27) Back Tension Gauge (DA09055A)
- (28) Tension Arm Adjustment Cassette (DA09056A)
- (29) Audio Analyzer T-100  
(including Distortion, Wow/Flutter, Speed, Oscillator and dB meter)

Notes: 1. (10) – (29) are the products of Nakamichi Corporation.

2. EH Stroke Check Gauge M-9042 (DA09042A) should be used for the Models serial Nos. from A30701001 to A30702750, and EH Stroke Check Gauge M-9051 (DA09051A) is for the Models bearing serial Nos. A30702751 and greater.

3. Back Tension Gauge (DA09055A) and Tension Arm Adjustment Cassette (DA09056A) are used for the Models bearing serial Nos. A30704141 and greater.

## 4. MECHANICAL ADJUSTMENTS

### 4.1. Mechanism Control Cam Adjustment

Before adjustment, disassemble the Front Panel Ass'y, then remove the Cover Plate Ass'y referring to items 2.5 and 2.21.

#### (1) Offset Adjustment of Control Motor Driver

- (a) Refer to Figs. 4.1 and 4.2.  
Adjust VR402 and VR403 on the Logic P.C.B. to locate approximately at the middle of the variable range. Then turn ON the Power Switch.  
VR402 (for Cam Position Stop)  
VR403 (for Cam Position Play)
- (b) Press the Stop Switch to set the N-660ZX in stop mode.  
Adjust VR402 (for Stop) so that the "S" mark on the Cam corresponds to the pointer on the mechanism chassis.
- (c) Press the Play Switch to set the N-660ZX in playback mode.  
(Cam will rotate, and the position marked with "PY" comes to the pointer.)  
Adjust VR403 (for Play) so that the "PY" mark on the Cam corresponds to the pointer.
- (d) Repeat above (b) and (c) 2 – 3 times so that the "S" and "PY" marks on the Cam correspond to pointer accurately in stop and playback modes respectively. (This adjustment is required because the position adjusted by one volume will be slightly changed when the other volume is adjusted.)
- (e) Set the N-660ZX in FF, pause, record, or cue mode by pressing each switch (press FF and Pause Switches to set the N-660ZX in cue mode) and check to insure that the pointer is in a range of "F", "PS", "R", or "CU" mark respectively.
- (f) If out of the range, precise adjustment for each position according to "(2) Offset Fine Adjustment of Control Motor Driver" will be required.

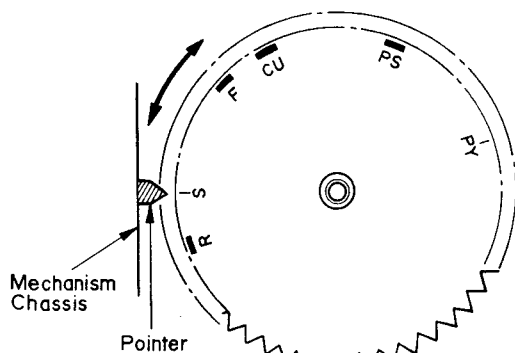

Fig. 4.1

#### (2) Offset Fine Adjustment of Control Motor Driver

Adjust only if a satisfactory result is not obtained in "(1) Offset Adjustment of Control Motor Driver".

This adjustment is made by changing the value of the fixed resistors on the Logic P.C.B. (Note: The value of voltage is typical value.)

#### (a) Observation Point of Reference Voltage

Observe the each voltage at the sliding contact of the Cam Control Volume VR405 (10 kΩ) in stop, fast (FF or REW), pause, record and playback modes.

Note: When Record and Play Switches are pressed to set N-660ZX in record mode, the Cam is first set to the record position in a short period of time then stays at the play position. Therefore to keep the Cam at the record position, following procedure is required:

Short the both leads of capacitor C450 (4.7 μF 25 V) on the Logic P.C.B. with a jumper wire, then press the Record and Play Switches.

#### (b) Reference Voltage

Reference voltage at the sliding contact of VR405 (Cam Control Volume) in each mode is as follows:

Mode	Reference Voltage (Typical Value)
Record	4.1 V
Stop	3.0 V
Fast (FF/REW)	1.3 V
Pause	-2.8 V
Play	-5.4 V

Additional voltage ranges shown in the diagram:

- Record: 1.1 V ±0.4 V
- Stop: 1.7 V ±0.25 V
- Pause: 2.6 V ±0.4 V

#### (c) Resistors for Adjustment

Mode	Ref. No.	Typical Value
Stop	R461	9.1 kΩ (F)
Fast (FF/REW)	R462	4.32 kΩ (F)
Pause	R445	287 kΩ (F)
Play	R443	174 kΩ (F)
Record	R601	27 kΩ

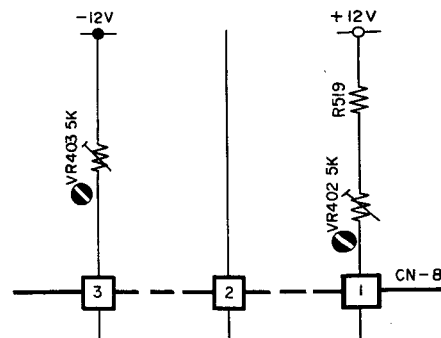

Fig. 4.2

**(d) Adjustment Procedures**

- 1) Press the Stop Switch to set the N-660ZX in stop mode.

Adjust the value of R461 to obtain 3.0 V ( $\pm 0.6$  V) at the sliding contact of VR405.

Note: When R461 is adjusted, the reference voltage in fast (FF or REW) mode is changed. Therefore, re-check of the reference voltage in fast (FF or REW) mode is required.

If the reference voltage is out of the range, re-adjustment of R462 according to next step 2) is necessary.

- 2) Set the N-660ZX in FF mode, then adjust the value of R462 so that the voltage of VR405 will become lower by 1.7 V ( $\pm 0.25$  V) than in stop mode.
- 3) Press the Pause Switch to set the N-660ZX in pause mode.  
Adjust the value of R445 to obtain  $-2.8$  V ( $+0.4$ ,  $-0.15$  V) at the sliding contact of VR405.
- 4) Set the N-660ZX in playback mode, then adjust the value of R443 so that the voltage of VR405 will become lower by 2.6 V ( $\pm 0.4$  V) than in pause mode.
- 5) Short the both leads of capacitor C450 with a jumper wire.  
Set the N-660ZX in record mode, then adjust the value of R601 so that the voltage of VR405 will become higher by 1.1 V ( $+0.4$ ,  $-0.2$  V) than in stop mode.

Note: Remove the short of C450 after completion of adjustment.

**(3) Cam Timing Adjustment**

- (a) Remove the wires from the Control Motor Terminals to set the motor open.
- (b) Without loading a cassette tape and with pressing the Record Protecting Switch with your finger tip, press the Record and Play Switches to set the N-660ZX in record mode.
- (c) Turn the Cam and bring the "PY" mark toward the pointer by hand.  
Reel Motor will rotate before the "PY" mark reaches the pointer. Adjust the value of R483 and R484 so that the voltage at the sliding contact of VR405 becomes  $-3.6$  V ( $\pm 0.3$  V) when Reel Motor starts rotation.
- (d) Observe the mute signal at the Q418 collector.  
Turn the Cam referring to above step (c) and check to insure that the voltage at the sliding contact of VR405 is  $-3.8$  V ( $\pm 0.3$  V) when mute is released (mute signal changes from H to L). (This voltage is determined by the adjustment of R483 and R484 in above step (c).)
- (e) Observe the  $\overline{\text{Rec}}$  signal at the Q417 collector.  
Turn the Cam referring to above step (c) and adjust the value of R488 to obtain  $-2.1$  V ( $\pm 0.4$  V) at the sliding contact of VR405 when  $\overline{\text{Rec}}$  signal

changes from H to L (bias oscillation will begin).

- (f) Upon completion of above adjustment, re-connect wires to the motor terminals.

**4.2. Tape Speed Adjustment**

- (1) Remove the Top Cover.
- (2) Connect a Frequency Counter to the Output Jack.
- (3) Load a 3 kHz Speed Wow/Flutter Tape (DA09006A) and play it back.
- (4) Referring to Fig. 4.3, adjust the Tape Speed Adjustment Volume VR407 on the Speed Cal. P.C.B. to obtain 3,000 Hz on the Frequency Counter.

CCW: Motor drives slowly.

CW: Motor drives fast.

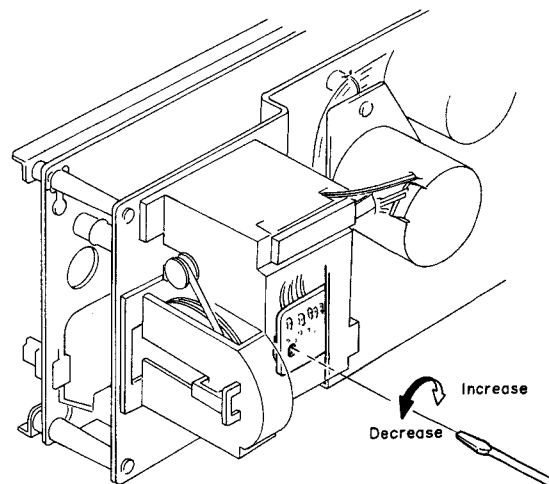

Fig. 4.3

### 4.3. Record Head and Playback Head Tilt Adjustment

Note: On items 4.3–4.9, please refer to Fig. 4.4 flow chart.

Refer to Figs. 4.5 and 4.6.

- (1) Load a Tilt Check Gauge M-9039 (DA09039A) in the N-660ZX.
- (2) Clip the grounding terminal of the Tilt Check Gauge with one end of the cord with clip, and the other end to the chassis of the N-660ZX.
- (3) Remove both of the Height Gears.
- (4) Set the N-660ZX in play mode. Check to insure whether the Beacons Playback Head "Upper" or "Lower" and Record Head "Upper" or "Lower" are illuminating. In order not to give damages onto the head surfaces, push both of slide knobs of the Gauge to the direction of arrow marks, then return it to the original place to be in contact with record head and playback head surfaces after play mode is se-

curely locked.

- (5) Check to insure freedom from contact between the Gauge and pad lifter.
- (6) Beacon Playback Head "Lower" will light on when height adjustment screw (P) turned clockwise but Playback Head "Upper" when counterclockwise. Adjust so that both "Upper" and "Lower" will light on even when you move the slide knob to the direction of an arrow mark and then return it to the original place.
- (7) Same procedures will apply to the Beacons Record Head "Upper" and "Lower", except for the height adjustment screw (R).
- (8) Set the N-660ZX in stop mode and fit both of the serrated height gears. Then set the N-660ZX again in play mode and insure all of the 4 Beacons are illuminating. If not, (3) through (7) will have to be repeated till satisfactory results are obtained.

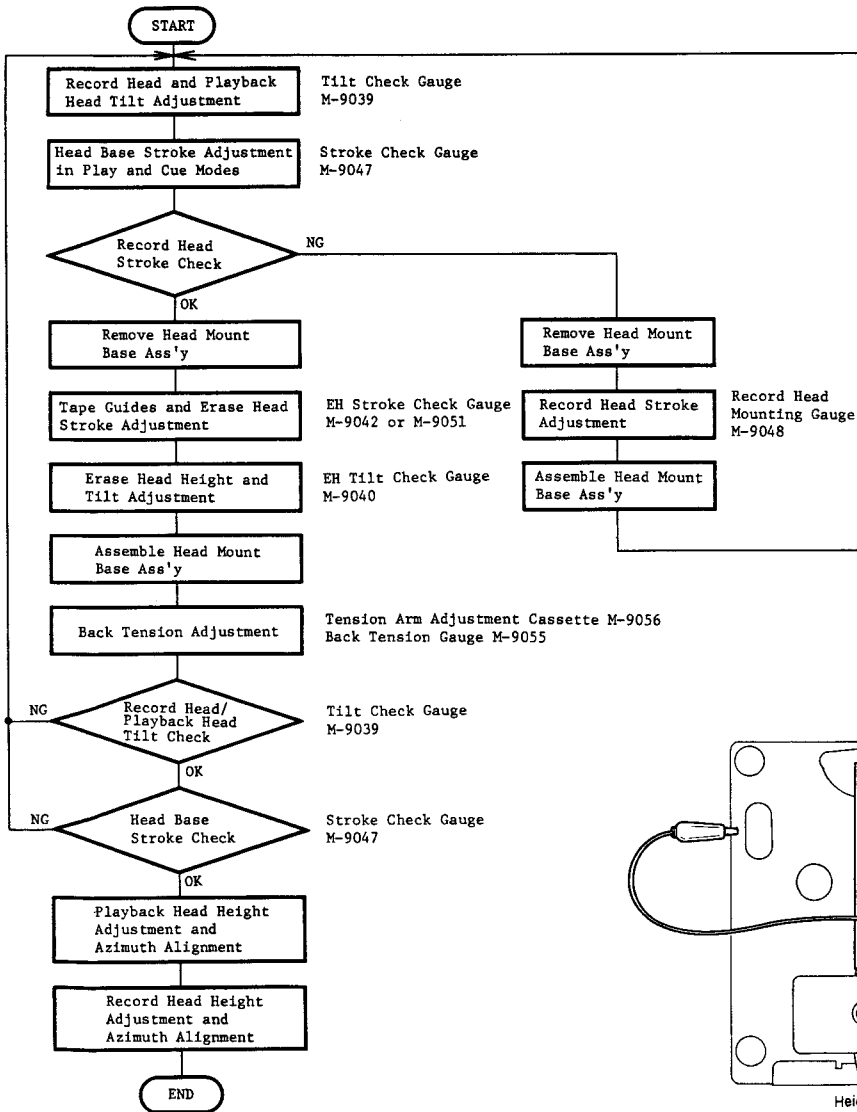

Fig. 4.4

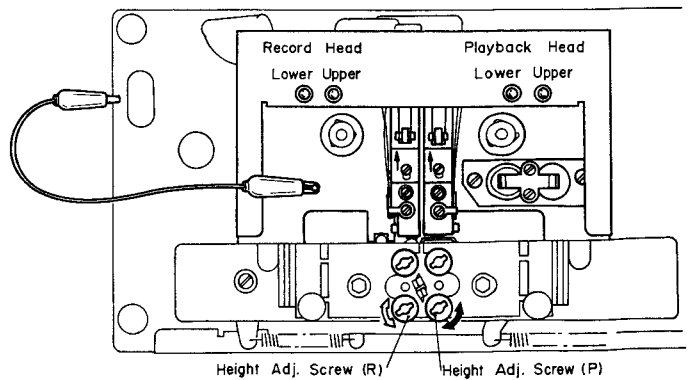

Fig. 4.5

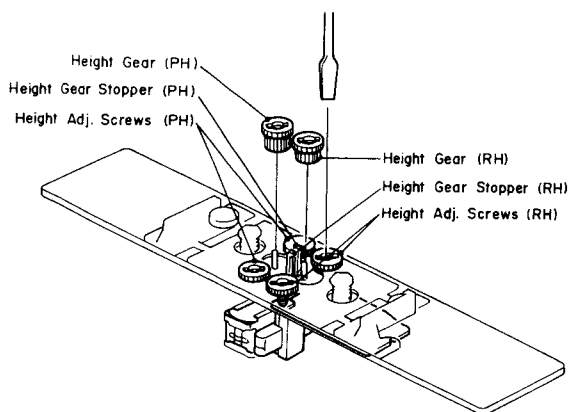

Fig. 4.6

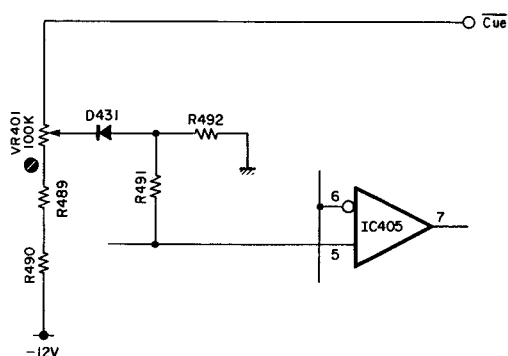

Fig. 4.8

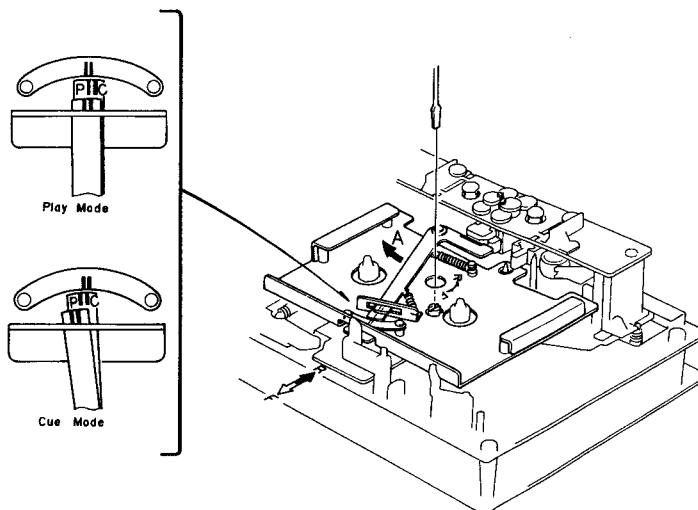

Fig. 4.7

#### 4.4. Head Base Stroke Adjustment in Play and Cue Modes

Note: Before you conduct this adjustment, adjust with a "Tilt Check Gauge" to insure freedom from tilt on the playback head and record head.

##### (1) Head Base Stroke Adjustment in Play Mode

Refer to Fig. 4.7.

- Load a Stroke Check Gauge M-9047 (DA09047A) in the N-660ZX.
- Move Record Head Indicator and Playback Head Indicator to the direction of arrow mark "A" with your finger tip and then set the N-660ZX in play mode. Then slowly release the Indicators and insure whether each of the Indicators is in contact with record and playback heads.
- Check to insure whether the "P" pointer on the Playback Head Indicator locates between the 2 lines on the Indicator Plate.
- If the playback head stroke is noted to be misaligned, adjustment can be made by moving the stroke adjuster assembled in the head base assembly (either forwardly or backwardly).
- Check to insure whether the "P" pointer on the Playback Head Indicator locates between the 2 lines on the Record Head Indicator, thus check can be made on record head stroke.

- If the record head stroke is noted to be misaligned, adjustment can be made with a Record Head Mounting Gauge M-9048 (DA09048A).

##### (2) Head Base Stroke Adjustment in Cue Mode

Refer to Fig. 4.8.

- Load a Stroke Check Gauge M-9047 (DA09047A) in the N-660ZX.
- Move Record Head Indicator and Playback Head Indicator to the direction of arrow mark "A" with your finger tip and then set the N-660ZX in cue mode (F.F. and Pause). Then slowly release the Indicators and insure whether each of the Indicators is in contact with record and playback heads.
- Check to insure whether the "C" pointer on the Playback Head Indicator locates between the 2 lines on the Indicator Plate.
- If the playback head stroke is noted to be misaligned, adjust VR401 on the Logic P.C.B. Ass'y till satisfactory results are obtained.
- After completion of the Head Base Stroke Adjustment, check to insure accuracy of the Head Base Stroke Adjustment in play mode. If the above are inaccurate, items (1) and (2) will have to be repeated till satisfactory results are obtained.

## 4.5. Tape Guides Adjustment and Erase Head Stroke Adjustment

Remove Head Mount Base Ass'y referring to item 2.30. Refer to Figs. 4.9 and 4.10.

### (1) Supply Tape Guide Height Adjustment

- (a) Load an EH Stroke Check Gauge M-9042/M-9051 in the N-660ZX.
- (b) Set the N-660ZX in play mode.
- (c) Slide the Supply Tape Guide Check Bar down against the supply tape guide, thus check can be made on supply tape guide height.
- (d) If the supply tape guide is misaligned, the Supply Tape Guide Check Bar will not come into the supply tape guide. If such is noted, turn to adjust the height adjustment nut A till the Supply Tape Guide Check Bar is accepted by the supply tape guide.
- (e) If the above are insured, set the N-660ZX in pause mode, then in play mode to see whether adjustments are appropriately made. If not, (b) through (e) will have to be repeated till satisfactory results are obtained.

### (2) Take-up Tape Guide Height Adjustment

- (a) Load an EH Stroke Check Gauge M-9042/M-9051 in the N-660ZX.
- (b) Set the N-660ZX in play mode.
- (c) Slide the Take-up Tape Guide Check Bar down against the take-up tape guide, thus check can be made on take-up tape guide height.
- (d) If the take-up tape guide is misaligned, the Take-up Tape Guide Check Bar will not come into the take-up tape guide. If such is noted, turn to adjust the height adjustment nut B till the Take-up Tape Guide Check Bar is accepted by the take-up tape guide.
- (e) If the above are insured, set the N-660ZX in pause mode, then in play mode to see whether adjustments are appropriately made. If not, (b) through (e) will have to be repeated till satisfactory results are obtained.

### (3) Erase Head Stroke Adjustment

- (a) Load an EH Stroke Check Gauge M-9042/M-9051 in the N-660ZX.
- (b) Set the N-660ZX in play mode, thus check can be made on erase head stroke through the EH Stroke Indicator.
- (c) Check to insure whether the erase head surface is aligned with red line on the EH Stroke Indicator. If not, adjust the erase head stroke by loosening 2 screws that assembled erase head and erase head plate.
- (d) After completion of adjustment, 2 pcs. of screws shall be locked with lock tight paint.

Note:

EH Stroke Check Gauge M-9042 (DA09042A) should be used for the Models serial Nos. from A30701001 to A30702750, and EH Stroke Check Gauge M-9051 (DA-09051A) is for the Models bearing serial No. A30702751 and greater.

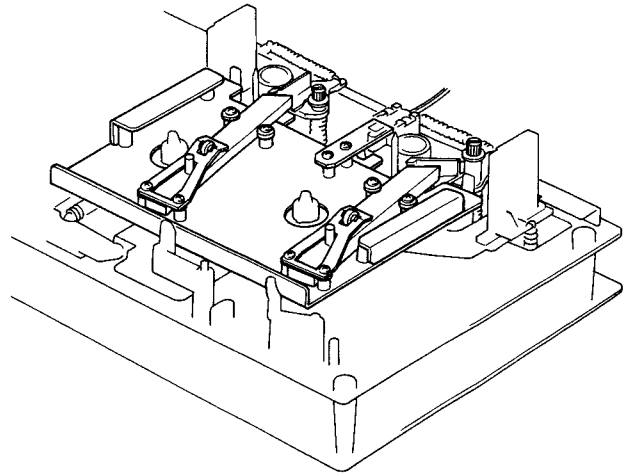

Fig. 4.9

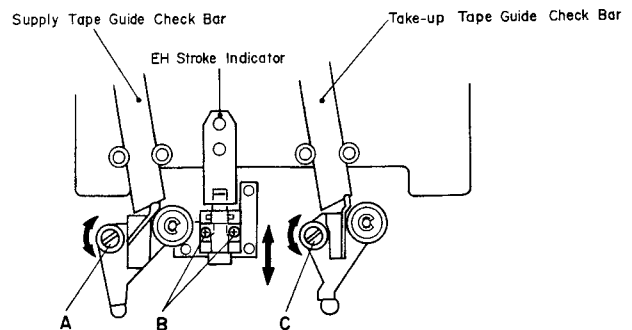

Fig. 4.10

## 4.6. Erase Head Height and Tilt Adjustment

Refer to Figs. 4.11 and 4.12.

- (1) Remove Head Mount Base Ass'y referring to item 2.30.
- (2) Load an EH Tilt Check Gauge M-9040 (DA09040A) in the N-660ZX.
- (3) Set the N-660ZX in stop mode.
- (4) Check to insure whether one of the 3 Beacons is illuminating. Look down the mirror as shown by an arrow mark and slowly turn the Screw "Height" counterclockwise (or clockwise) so that the two horizontal lines on the mirror will become superposed on the line (in different color) of the erase head, and check to insure whether Beacon "1" is illuminating.



- (5) Turn Screw "Tilt" counterclockwise (or clockwise) to light on Beacon "2". Excessive turning will cause the Beacon "1" to light off. Adjustments of Screw "Tilt" will therefore be conducted till both of the Beacons "1" and "2" illuminate.
- (6) Turn Screw "Azimuth" counterclockwise (or clockwise) to light on Beacon "3". Excessive turning will cause either Beacon "1" or "2" to light off, and therefore adjust with Screw "Azimuth" until all of the 3 Beacons "1", "2" and "3" illuminate.

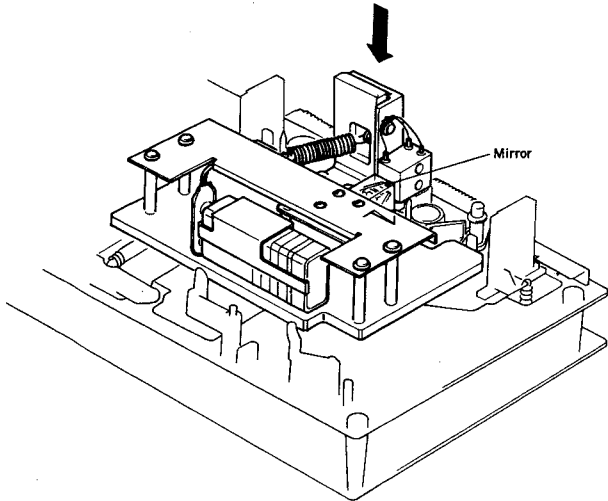

Fig. 4.11

- (7) Check to insure whether the horizontal line on the mirror corresponds to that on the erase head. If not, (4) through (7) will have to be repeated till satisfactory results are obtained.
- (8) After completion of adjustment, 3 pcs. of screws shall be locked with lock tight paint.

Note: Before use of this gauge, check to insure freedom from dust or dirt, or overflow in the groove of the erase head surface.

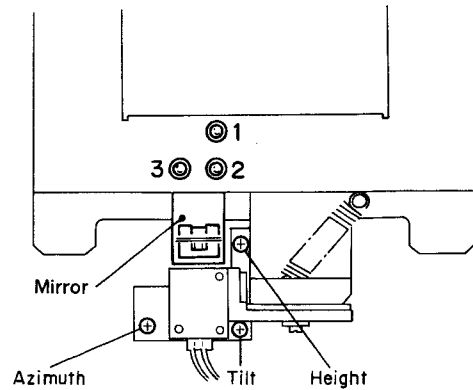

Fig. 4.12

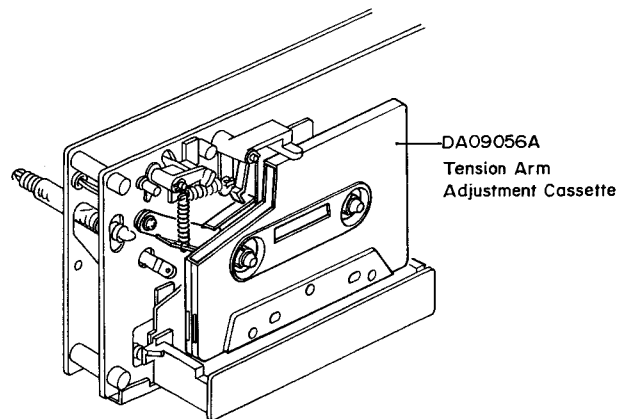

Fig. 4.13

#### 4.7. Back Tension Adjustment

Note: This adjustment is required for the Models bearing serial Nos. A30704141 and greater.

Refer to Figs. 4.13 – 4.16.

- (1) Load a Tension Arm Adjustment Cassette (DA 09056A) referring to Fig. 4.13.
- (2) Set the N-660ZX in play mode.
- (3) Bend the Back Tension Arm with pliers so that the gap between the Cassette Holding Spring assembled with the Head Base Ass'y and the Back Tension Arm becomes 0.5 mm as shown in Fig. 4.14. Do not bend the pointed end of the Back Tension Arm.

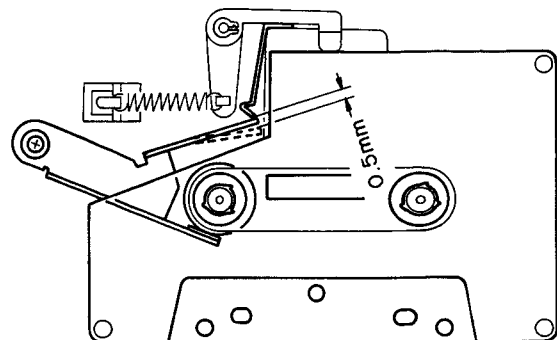

Fig. 4.14

- (4) Set the N-660ZX in stop mode, and remove the Tension Arm Adjustment Cassette (DA09056A), then set the N-660ZX in cue mode.

In cue mode, check to insure that the gap is found between the Supply Reel Hub B Ass'y and the Felt of Back Tension Ass'y as shown in Fig. 4.15.

- (5) Load a Back Tension Gauge (DA09055A).
- (6) Set the N-660ZX in play mode and read the torque value of Back Tension Gauge.

If the value is in a range of 6 g-cm to 10 g-cm, adjustment is not necessary. If not, change the installation point of the Back Tension Spring as shown in Fig. 4.16, and obtain the torque of 7 g-cm to 9 g-cm range.

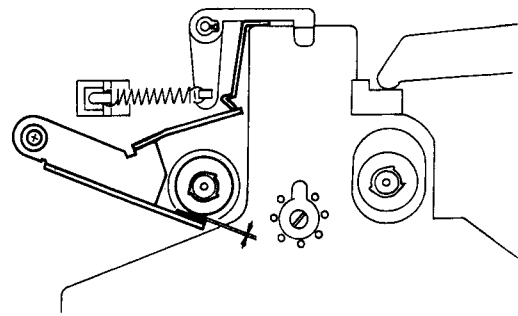

Fig. 4.15

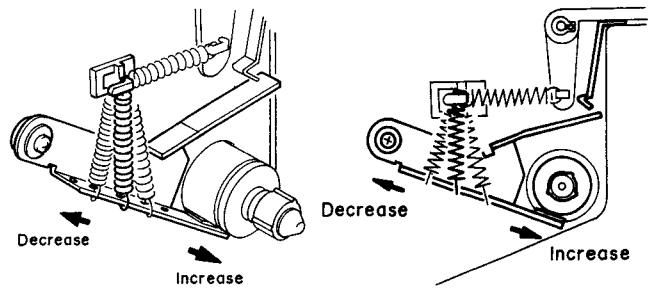

Fig. 4.16

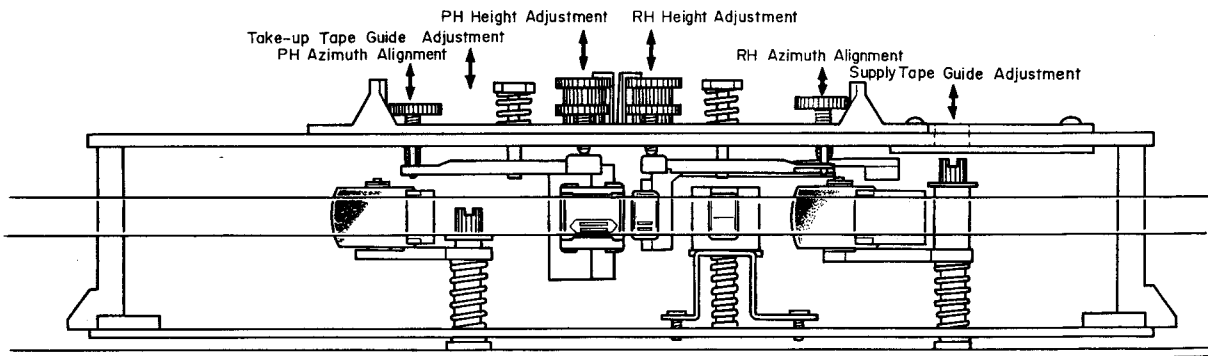

Fig. 4.17

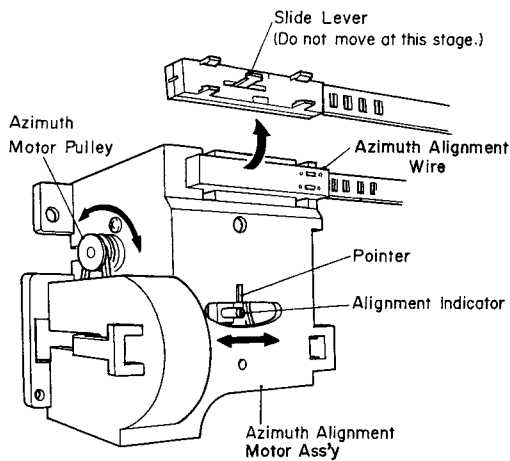

Fig. 4.18

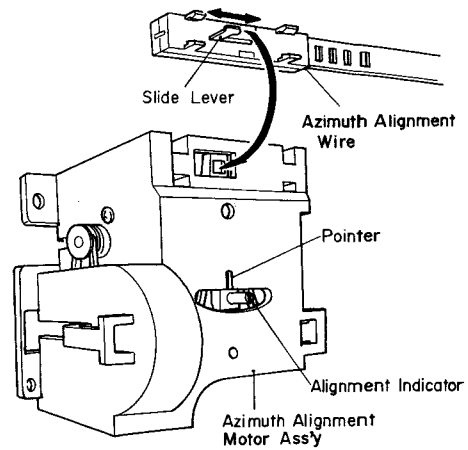

Fig. 4.19

#### 4.8. Playback Head and Record Head Height Adjustment and Azimuth Alignment

##### (1) Playback Head Height Adjustment and Azimuth Alignment

Refer to Fig. 4.17.

- (a) Connect a VTVM to the Output Jacks.
- (b) Load a 1 kHz Track Alignment Tape (DA09007A), then set the N-660ZX in play mode.
- (c) Turn the PH Height Gear until the outputs of both channels become minimum.
- (d) Load a 15 kHz Azimuth Tape (DA09004A), then set the N-660ZX in play mode.
- (e) Turn the PH Azimuth Alignment Screw until the outputs of both channels become maximum.
- (f) Repeat above steps (b) through (e) one or two times to obtain optimum performance.

##### (2) Record Head Height Adjustment and Azimuth Alignment

Refer to Figs. 4.17 – 4.20.

- (a) Set the N-660ZX in stop mode.  
Turn the Azimuth Motor in the Azimuth Alignment Motor Ass'y by hand so that the Alignment Indicator corresponds to the pointer of the Azimuth Alignment Motor Ass'y as shown in Fig. 4.18.  
Remove the Azimuth Alignment Wire by pulling out from the Azimuth Alignment Motor Ass'y. In this case, do not move the Slide Lever of the Azimuth Alignment Wire. Short both leads of capacitor C903 on the Auto Azimuth P.C.B. Ass'y with a jumper wire.
- (b) Connect a VTVM to the Playback Eq. Amp. Outputs, terminals 29 (L ch) and 30 (R ch) on the Main P.C.B. Ass'y, or terminals 1 (L ch) and 2 (R ch) on the Auto Azimuth P.C.B. Ass'y.
- (c) Load a Reference SX Tape (DA09025A). Set the Eq. Switch to the 70  $\mu$ s position and Tape Switch to the SX position. Then set the N-660ZX in record and play mode.
- (d) Set the Auto. A/Tone Switch to the Cal. position, then turn the RH Height Gear until the outputs of both channels become maximum.
- (e) Feed in 15 kHz (-20 dB), then set the N-660ZX in record and play mode. Turn the RH Azimuth Alignment Screw until the outputs of both channels become maximum.
- (f) Repeat above steps (d) and (e) one or two times to obtain optimum performance.
- (g) After completion of the above adjustments, perform the following electrical adjustment by using the same side of the same tape as used in the above steps.
  - 1) Set the Auto. A/Tone Switch to the Cal. position, then set the N-660ZX in record and play mode.
  - 2) Adjust VR901 on the Auto Azimuth P.C.B. Ass'y so that the Azimuth Motor stops its rotation.

- (h) Set the N-660ZX in stop mode.

Mount the Azimuth Alignment Wire on the Azimuth Alignment Motor Ass'y referring to Fig. 4.19. (Correct the position of the Slide Lever of the Azimuth Alignment Wire by sliding by hand, then insert the Slide Lever into the receptacle of the Azimuth Alignment Motor Ass'y).

Remove the shorting jumper wire from C903 on the Auto Azimuth P.C.B. Ass'y.

- (i) After completion of the above adjustments, record 400 Hz tone to the same portion of both side A and side B of the tape.
- (j) Immerse the recorded tape in a magnetized developing solution. In turn, check to insure that the recording head tracks across the center are separated with a distance of 0.55 to 0.75 mm (typically 0.65 mm) as illustrated in Fig. 4.20.

Note: Liquid for tape magnetized development solution

"MAGNA-SEE, SOUND CRAFT a product of CBS RECORD a division of Columbia Broadcasting System, Inc., Danbury, Conn. 06810 U.S.A., or equivalent".

After development, clean the tape otherwise pressure rollers and heads will become dirty.

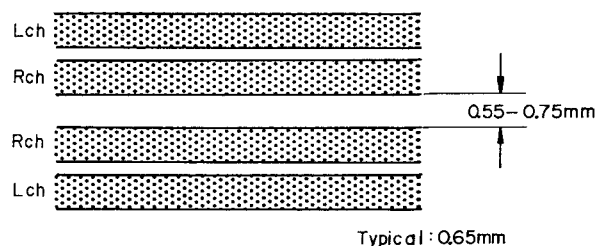

Fig. 4.20

## 4.9. Record Head Stroke Adjustment

Refer to Figs. 4.21 and 4.22.

Note: This adjustment will be required only to insure freedom from misalignment of the record head stroke in the record head stroke check mode.

- (1) Check the accuracy of the record head stroke.
- (2) Remove Head Mount Base Ass'y referring to item 2.30.
- (3) Remove the record head assembly.
- (4) Adjustment of Record Head Mounting Gauge M-9048 (DA09048A)
  - (a) Mount the Block B onto the Mounting Gauge Plate.
  - (b) Loosen the 2 screws fixing the Block A.
  - (c) As shown in Fig. 4.21 hold the Gauges (3.05 mm and 0.1 mm thickness) between the Block A and Block B, fix the Block A with screws, pushing the Block A to the 2 guide pins.
- (5) Remove the Block B from the Mounting Gauge Plate.
- (6) As shown in Fig. 4.22, mount the R-8L record head assembly onto the Mounting Gauge Plate, then check the location of the R-8L record head surface. (If record head contacts to the Block C, loosen 2 pcs. of screws that assembled record head and R-8L record head assembly, then place the R-8L record head assembly onto the Plate.)
- (7) Remove the R-8L record head assembly from the Mounting Gauge Plate.

- (8) Readjustment of Record Head Mounting Gauge M-9048 (DA09048A)

- (a) Mount the Block B onto the Mounting Gauge Plate.
- (b) Loosen the 2 screws fixing the Block A.
- (c) As shown in Fig. 4.21 hold the Gauges (3.05 mm and either one of 0.05, 0.15, 0.2, 0.25, 0.3 or 0.35 mm thickness) between the Block A and Block B, fix the Block A with screw, pushing the Block A to the 2 guide pins.
- (9) Remove the Block B from the Mounting Gauge Plate.
- (10) Mount the R-8L record head assembly onto the Mounting Gauge Plate.
- (11) As shown in the Fig. 4.22, loosen the R-8L record head with 2 pcs. of screws onto the record head plate. As the location of the Block A is secured by the item (8)-(c), push the record head to the directions A and B, then tighten 2 pcs. of screws.
- (12) Check to insure freedom from gap between the Block C and record head surface, then tighten the 2 pcs. of screws on the record head plate with lock tight paint.
- (13) Assemble the record head assembly to the head mount base assembly.
- (14) Assemble the head mount base assembly to the mechanism assembly.
- (15) Check the record head stroke.  
If the above are inaccurate, items (1) through (15) will have to be repeated till satisfactory results are obtained.

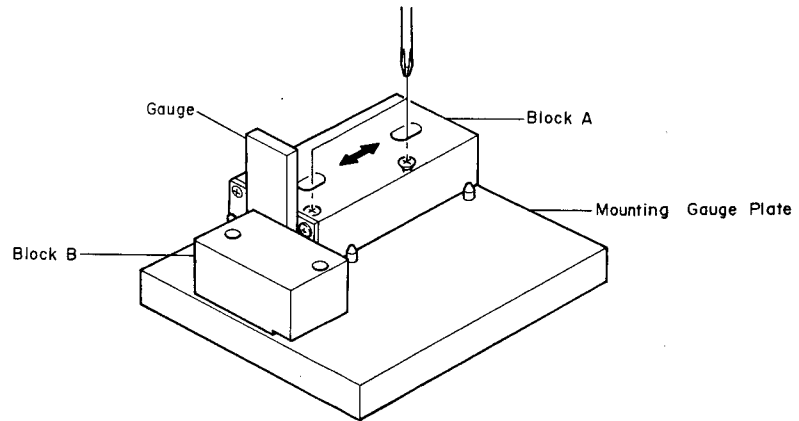
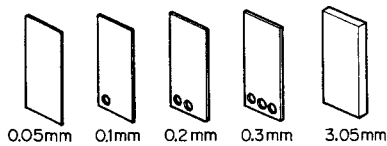

Fig. 4.21

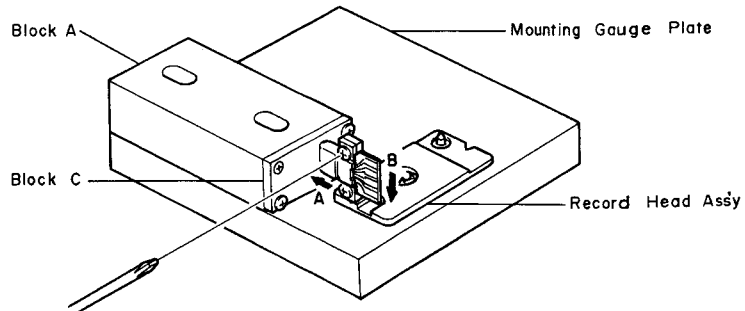

Fig. 4.22

#### 4.10. Tape Travelling Adjustment

The adjustment shall be made with a modified version of the current type EXII C-90 as shown in Fig. 4.23 (error will be made if a current type Tape Travelling Cassette (DA09011A) should be used for this purpose).

While modifying an EXII C-90, the tape guides in the cassette housing shall be kept protected to avoid tilt. Check shall be made in the following procedures:

- (1) An EXII C-90 Tape thus modified shall be loaded onto the N-660ZX.
- (2) Release the back-tension (rotate the Supply Reel and feed out some length of tape) and set the N-660ZX in play mode.
- (3) In this juncture, check to insure whether the tape is free from waving or slippage from the tape guide.
- (4) When the modified EXII C-90 is played back, check to insure whether the tape is freedom from waving from head surface or at pressure rollers.
- (5) If either of waving or slippage from the tape guide should be noted, adjustments of "4.3. Record Head and Playback Head Tilt Adjustment", "4.4. Head Base Stroke Adjustment", "4.5. Tape Guides Adjustment and Erase Head Stroke Adjustment", "4.6. Erase Head Height and Tilt Adjustment", "4.7. Back Tension Adjustment", "4.8. Playback Head and Record Head Height Adjustment and Azimuth Alignment", "4.9. Record Head Stroke Adjustment", etc. will be required.

As a case may be, the said waving or slippage may have been caused from defective Supply Pressure Roller Ass'y or Take-up Pressure Roller Ass'y without parallel contact with capstans. If such are noted, the Pressure Roller Assemblies will have to be replaced.

Further, excessively weak take-up torque or strong take-up torque may cause defective tape travelling.

The N-660ZX is intended to be an adjustment-free Model, however if the similar matters as above should be noted, please replace the Reel Hub Ass'y to obtain appropriate take-up torque.

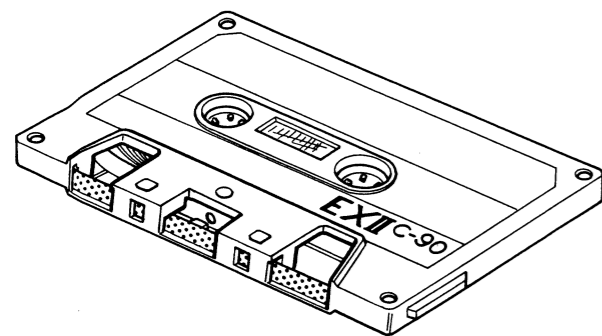

Fig. 4.23

#### 4.11. Record Switch Linkage Adjustment

- (1) Set the N-660ZX in stop mode.
- (2) Loosen the screw of the Record Spring Holder, and shift the Record Spring Holder in order to remove the looseness of the Linkage Wire as shown in Fig. 4.24.1. Then tighten the screw for fixing the Record Spring Holder. (In this case, the Record Switch should be positioned at Play side. If in the Record position, it will be defective.)
- (3) Set the N-660ZX in record and pause mode. Check to insure that the gap between the top of the wire and the Record Spring Holder is approx. 1 mm as shown in Fig. 4.24.2. (Check that the Record Switch is in Record position.)
- (4) Upon completion of the above adjustments, apply a quantity of lock tight paint.

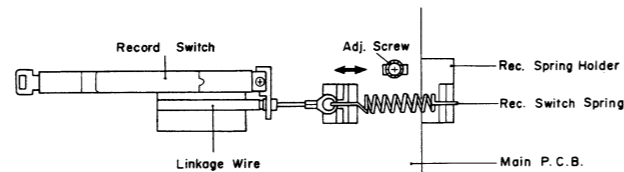

Fig. 4.24.1

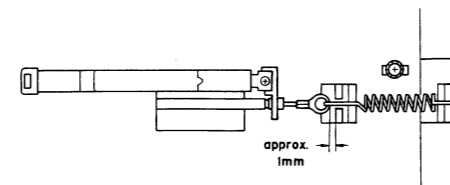

Fig. 4.24.2

#### 4.12. Flywheel Holder Adjustment

- (1) Refer to Fig. 4.25. Tighten the Thrust Screws until the gap between the Flywheel Assemblies and Thrust Screws becomes minimized when both of the Capstan Shafts are moved backwardly and forwardly (the Thrust Springs between the Capstan Flanges and Flywheel Thrust Caps are in a flat state). Excessive tightening of the Thrust Screws however will give damages on the Flywheel Assemblies, to which careful attention is invited.
- (2) Return the Thrust Screws by 1/2 turn.
- (3) Fixing the Thrust Screw with a screwdriver, lock the Lock Nut.
- (4) Apply a quantity of lock tight paint to the Thrust Screws.

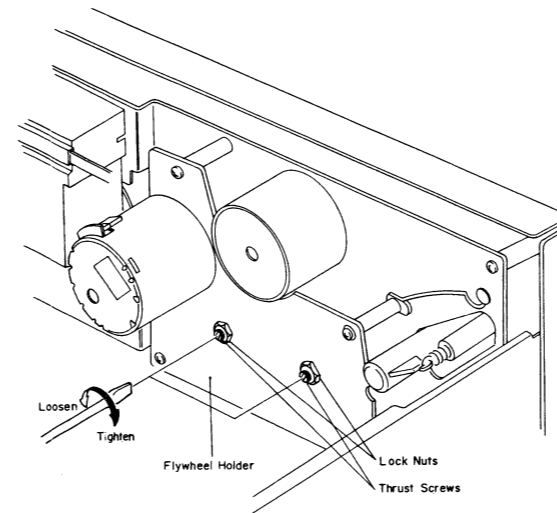

Fig. 4.25

#### 4.13. Lubrication

N-660ZX is a lubrication-free cassette deck except when parts are replaced. Apply the following lubricant for each replaced part:

- (1) LAUNA #100
  - Capstan Shaft
  - Pressure Roller Shaft
  - Thrust Cap
- (2) FLOIL GB-TS-1
  - Reel Hub Shaft
  - Thrust portion on the Capstan Shaft

FLOIL GB-TS-1, made by Kanto Chemicals Co., Ltd., in Japan.

We suggest you use the above or equivalent type. If unavailable please contact Kanto Chemicals Co., Ltd., 1-7 Kanda Suda-cho Chiyoda-ku, Tokyo 101 Japan.

- (3) Silicon Oil #3000 CST
  - Air Damper Piston

Note: Excessive lubrication may cause defective damper action as the 0.2φ hole at the end of the cylinder may be filled with oil.

5. PARTS LOCATION FOR ELECTRICAL ADJUSTMENT

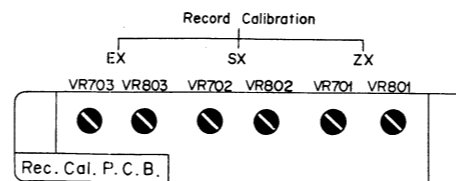
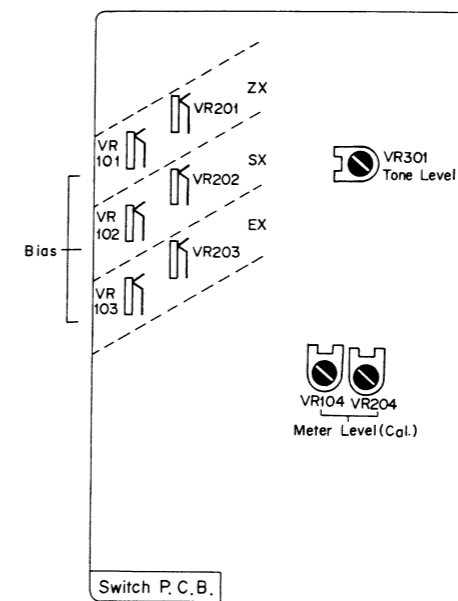
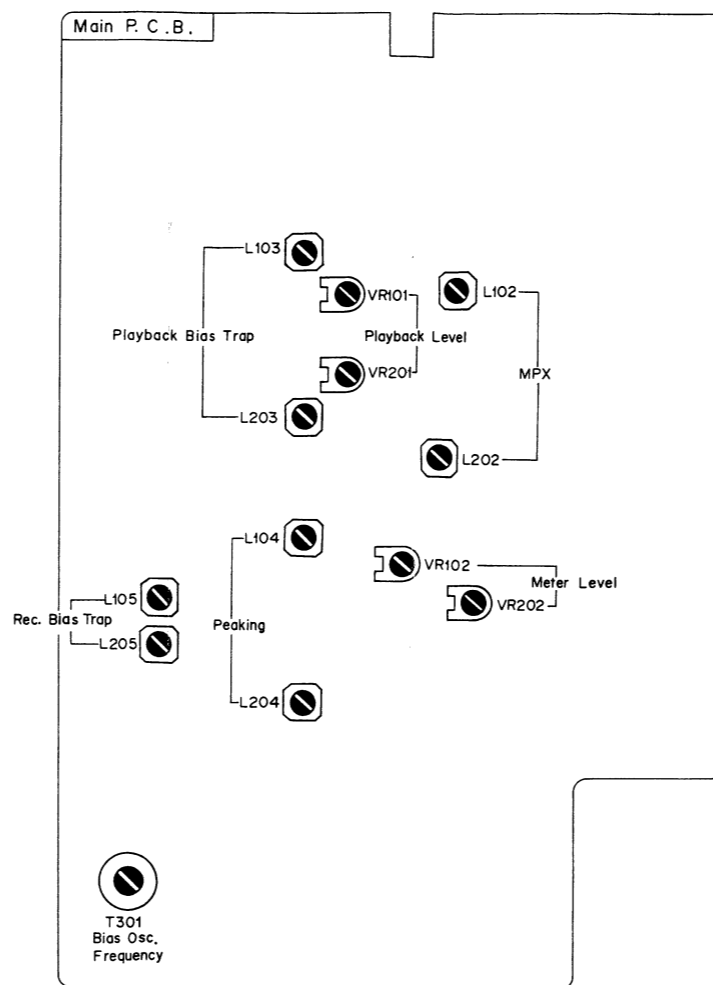
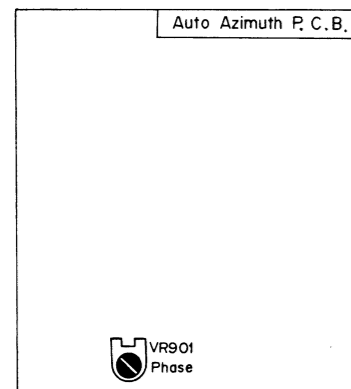
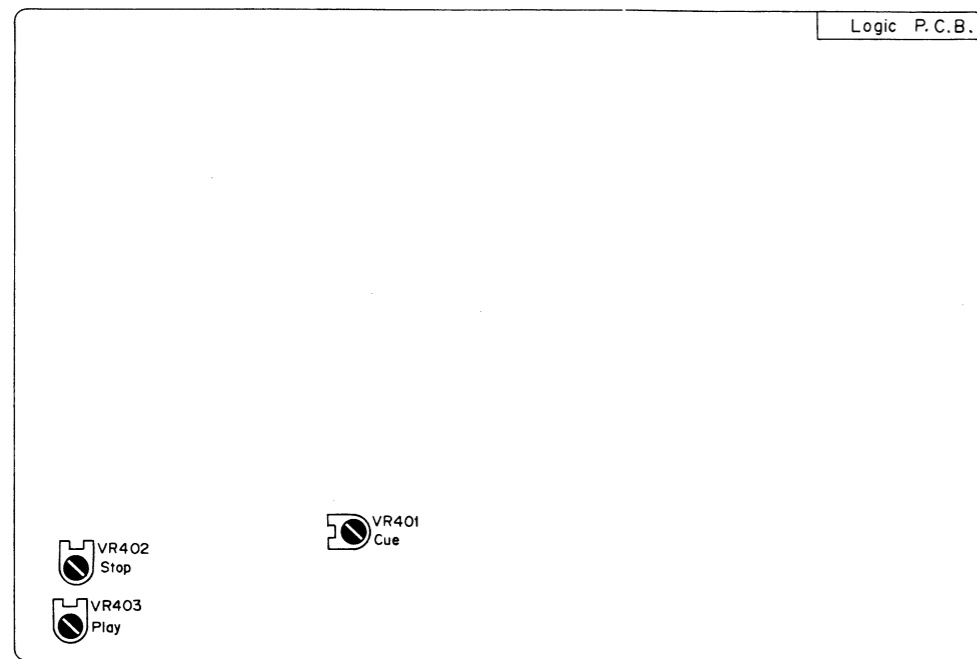

Fig. 5

6. ELECTRICAL ADJUSTMENTS AND MEASUREMENTS

6.1. Adjustment and Measurement Instructions

Note: Electrical adjustment should be performed after mechanical adjustment is completed.

STEP	ITEM	SIGNAL SOURCE	OUTPUT CONNECTION	MODE	ADJUSTMENT	REMARKS
1	Tape Speed	3 kHz Speed and Wow/Flutter Tape (DA09006A)	Frequency Counter to OUTPUT Jacks	Playback	Speed Cal. P.C.B. VR407	Adjust VR407 to obtain 3 kHz $\pm$ 0.5%.
2	Tone Calibration	Test Tone 400 Hz	VTVM to TP101 (A), TP201 (B) on the Main P.C.B.	Record, Pause Auto. A/Tone SW – CAL	Switch P.C.B. VR301	1. Set the Auto. A/Tone Switch to CAL. Turn output level control fully clockwise (maximum position). 2. Adjust VR301 to obtain 100 mV $\pm$ 0.2 dB at TP101 and TP201 on the VTVM.
3	Meter Level	400 Hz (0 dB/-10 dB/-20 dB) to INPUT Jacks	VTVM to TP101(A), TP201(B) on the Main P.C.B.	Record, Pause Auto. A/Tone SW – CAL/OFF	Main P.C.B. VR102, VR202	1. Adjust VR102 (VR202) to obtain 0 dB on the level meters at 100 mV level on the VTVM. 2. Decrease input level by 10 dB/20 dB then short or open R149 (R249) to obtain minimum deviation for -10 dB/-20 dB on the level meters. (Perform at -10 dB and -20 dB.) 3. Again increase input level so that output will become 100 mV, then re-adjust VR102 (VR202) to obtain 0 dB on the level meters.
4	MPX Filter	19 kHz $\pm$ 100 Hz to INPUT Jacks	VTVM to OUTPUT Jacks	Auto. A/Tone SW – OFF Dolby NR SW – OUT/MPX	Main P.C.B. L102, L202	1. Turn output level control fully clockwise (maximum position). 2. Adjust input level control to obtain 1 V on the VTVM. 3. Set the Dolby NR Switch to MPX position, then adjust L102 (L202) to obtain minimum reading on the VTVM (minimum reading will be less than -30 dB).
5	Playback Head Track Alignment	1 kHz Track Alignment Tape (DA09007A)	VTVM to OUTPUT Jacks	Playback Auto. A/Tone SW – OFF Eq. SW – 70 $\mu$ s Dolby NR SW – OUT	Playback Head Height Adj. Screw	Adjust the Playback Head Height Adj. Screw to obtain minimum reading of both L and R channels on the VTVM. See "Playback Head Height Adjustment and Azimuth Alignment" in item 4.8.
6	Playback Head Azimuth Alignment	15 kHz Azimuth Tape (DA09004A)	VTVM to OUTPUT Jacks	Same as above	Playback Head Azimuth Alignment Screw	Adjust the Playback Head Azimuth Alignment Screw to obtain maximum reading of both L and R channels on the VTVM. See "Playback Head Height Adjustment and Azimuth Alignment" in item 4.8. Note: Repeat steps 5 and 6 one or two times to obtain optimum performance.
7	Playback level	400 Hz Level Tape (DA09005A)	VTVM to TP101, TP201 on the Main P.C.B.	Same as above	Main P.C.B. VR101, VR201	Adjust VR101 (VR201) to obtain 100 mV on the VTVM or 0 dB on the level meters.

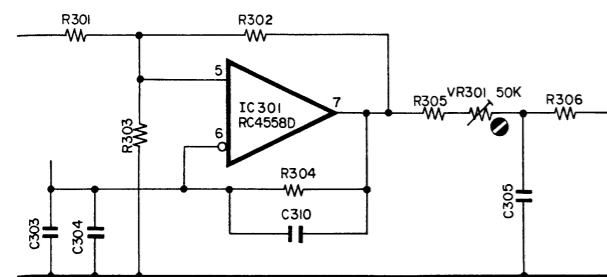

Fig. 6.1 2. Tone Calibration

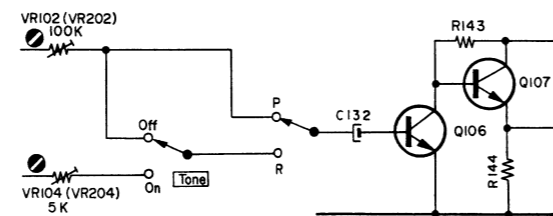

Fig. 6.2 3. Meter Level

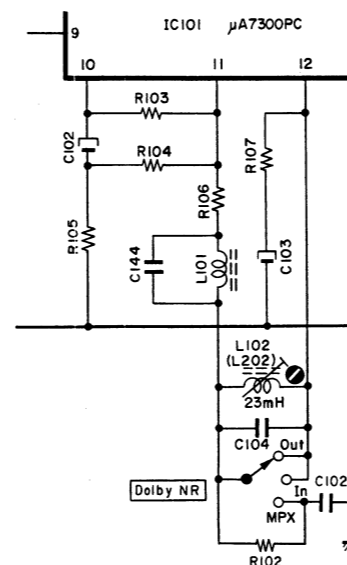

Fig. 6.3 4. MPX Filter

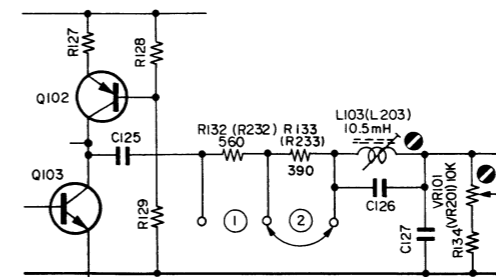

Fig. 6.4 7. Playback Level

STEP	ITEM	SIGNAL SOURCE	OUTPUT CONNECTION	MODE	ADJUSTMENT	REMARKS
8	Playback Frequency Response Adjustment	400 Hz Level Tape (DA09005A) 10 kHz PB Frequency Response Tape (DA09003A) 15 kHz PB Frequency Response Tape (DA09002A) 20 kHz PB Frequency Response Tape (DA09001A)	VTVM to OUTPUT Jacks	Playback Auto. A/Tone SW — OFF Eq. SW — 70 μs Dolby NR SW — OUT	Main P.C.B. R132, R232 R133, R233	<ol style="list-style-type: none"> <li>1. Load the 400 Hz level tape and play it back. Adjust the output level control to a certain level (for example 0 dB).</li> <li>2. Load the 10 kHz, 15 kHz and 20 kHz PB frequency response tapes and adjust the playback head azimuth to give maximum levels on the VTVM with each tape. Short R132 (R232) or R133 (R233) to obtain the following levels against 400 Hz level tape. Refer to Fig. 6.5. 10 kHz: -20 dB -1 dB to +2 dB 15 kHz: -20 dB -1 dB to +3 dB 20 kHz: -20 dB -1 dB to +4 dB</li> <li>3. Conduct step 6 "Playback Head Azimuth Alignment".</li> <li>4. If above is not sufficient, refer to "Playback Frequency Response Adjustment" in item 6.2.</li> </ol>
9	Bias Oscillation Frequency and Erase Current	Connect an additional 0.1 Ω resistor in series to the Erase Head	VTVM and Frequency Counter across the additional 0.1 Ω resistor	Record, Pause Tape SW — ZX Eq. SW — 70 μs Dolby NR SW — OUT	Main P.C.B. T301 R304, R305	<ol style="list-style-type: none"> <li>1. Adjust T301 to obtain 105 kHz on the frequency counter.</li> <li>2. Check the erase current by the VTVM. Erase current will be in a range of 310 mA to 400 mA (typically approx. 350 mA). If erase current is not sufficient, increase it by shorting R304 or R305.</li> <li>3. After completion of the erase current adjustment, recheck the bias oscillation frequency.</li> </ol>
10	Record Amplifier Equalizer	23 kHz (-20 dB) to INPUT Jacks	VTVM to CN2-1, CN2-3 on the Main P.C.B.	Record, Pause Auto. A/Tone SW — OFF Tape SW — ZX Eq. SW — 70 μs Dolby NR SW — OUT	Main P.C.B. L104, L204	<ol style="list-style-type: none"> <li>1. Remove the bias-cut-jumper from the dip side of the Main P.C.B.</li> <li>2. Adjust L104 (L204) to obtain peak reading at 23 kHz on the VTVM.</li> <li>3. Re-solder the bias-cut-jumper.</li> </ol>
11	Bias Trap (Record Amp.)	Remove input signals	Same as above	Same as above	Main P.C.B. L105, L205	Adjust L105 (L205) to obtain maximum reading on the VTVM.
12	Bias Trap (Playback Amp.)	Remove input signals	VTVM to Playback Eq. Amp. Output; Terminals 29, 30 on the Main P.C.B. or Terminals 1, 2 on the Auto Azimuth P.C.B.	Same as above	Main P.C.B. L103, L203	Adjust L103 (L203) to obtain minimum reading on the VTVM.

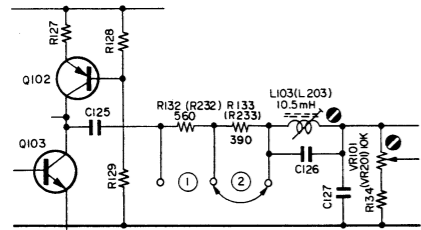

Fig. 6.5 8. Playback Frequency Response  
12. Bias Trap (Playback Amp.)

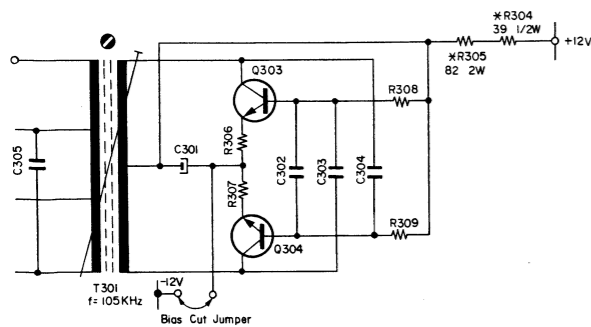

Fig. 6.6 9. Bias Oscillation Frequency and Erase Current

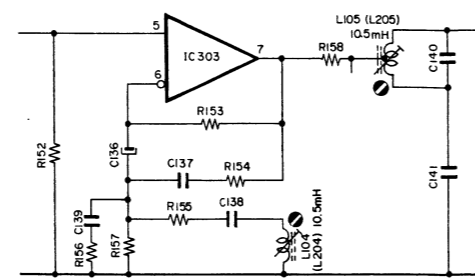

Fig. 6.7 10. Record Amp. Equalizer  
11. Bias Trap (Record Amp.)

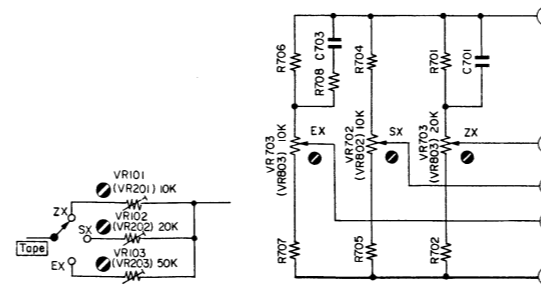

Fig. 6.8 13. Record Head Height and Azimuth

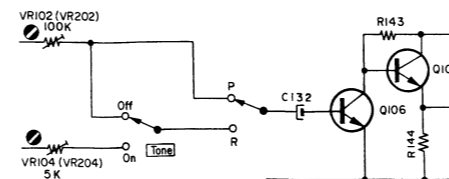

Fig. 6.9 13. Record Head Height and Azimuth

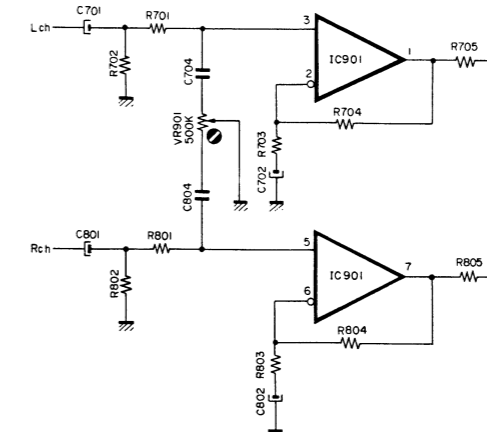

Fig. 6.10 13. Record Head Height and Azimuth



STEP	ITEM	SIGNAL SOURCE	OUTPUT CONNECTION	MODE	ADJUSTMENT	REMARKS
13	Record Head Height Adjustment and Azimuth Alignment	400 Hz (0 dB) and 15 kHz (-20 dB) to INPUT Jacks	VTVM to Playback Eq. Amp. Output; Terminal 29, 30 on the Main P.C.B. or Terminal 1, 2 on the Auto Azimuth P.C.B.	Record, Playback Auto. A/Tone SW - OFF/CAL Tape SW - SX Eq. SW - 70 $\mu$ s Dolby NR SW - OUT	Head Height: Record Head Height Adj. Screw  Azimuth Alignment: Record Head Azimuth Alignment Screws  Rec. Cal. P.C.B. (Level) VR702, VR802  Switch P.C.B. VR102, VR202 VR104, VR204  Auto Azimuth P.C.B. VR901	<ol style="list-style-type: none"> <li>In stop mode, turn the Azimuth Motor by hand so that the Alignment Indicator corresponds to the pointer of the Azimuth Alignment Motor Ass'y as shown in Fig. 4.18. Remove the Azimuth Alignment Wire by pulling out from the Azimuth Alignment Motor Ass'y. (In this case, do not move the Slide Lever of the Azimuth Alignment Wire.) Short both leads of capacitor C903 on the Auto Azimuth P.C.B. Ass'y with a jumper wire.</li> <li>Record Head Height Adjustment: <ol style="list-style-type: none"> <li>Set the Auto. A/Tone Switch to OFF.</li> <li>Feed in 400 Hz, then adjust input level controls to obtain 0 dB on the level meters.</li> <li>Record signals on the reference SX tape (DA09025A), then play it back.</li> <li>Adjust the Record Head Height Adj. Screw to obtain maximum readings of both channels on the VTVM.</li> </ol> </li> <li>Record Head Azimuth Alignment: <ol style="list-style-type: none"> <li>Set the Auto. A/Tone Switch to OFF.</li> <li>Feed in 400 Hz, then adjust input level controls to obtain 0 dB on the level meters.</li> <li>Record signals on the reference SX tape (DA09025A), then play it back.</li> <li>Adjust Record Cal. VR702 (VR802) to the center position.</li> <li>Adjust Bias VR102 (VR202) to obtain maximum reading on the VTVM.</li> <li>Adjust Record Cal. VR702 (VR802) to obtain the same reading as the source monitor level on the level meter.</li> <li>Decrease the Generator output level by 20 dB, then feed in 15 kHz (-20 dB).</li> <li>Record signals on the reference SX tape (DA09025A), then play it back.</li> <li>Adjust the Record Head Azimuth Alignment Screw to obtain maximum readings of both channels on the VTVM.</li> <li>Adjust finely VR102 (VR202) to obtain the same reading as the source monitor level on the VTVM.</li> <li>Repeat above substeps 2 and 3 one or two times to obtain optimum performance.</li> <li>Set the Auto. A/Tone Switch to CAL.</li> <li>Record signals on the reference SX tape (DA09025A), then play it back.</li> <li>Adjust VR901 so that the Azimuth Motor stops its rotation.</li> <li>Adjust VR104 (VR204) so that the level meter indicates 0 dB for both channels. (Note that this adjustment is required only when the Auto. A/Tone Switch is turned to the CAL position.)</li> </ol> </li> <li>After completion of above steps, mount the Azimuth Alignment Wire on the Azimuth Alignment Motor Ass'y. Remove the shorting jumper wire from C903 on the Auto Azimuth P.C.B. Ass'y.</li> <li>Check the Auto Azimuth Alignment function as follows: <ol style="list-style-type: none"> <li>Set the Auto. A/Tone Switch to OFF.</li> <li>Load a reference tape, then depress the Record Button and Play Button simultaneously to start recording.</li> <li>Change the Auto. A/Tone Switch to the CAL position and check to insure that the play lamp will keep flashing.</li> <li>After the flashing is completed, check to insure that the playback level is indicated on the level meter for both channels.</li> <li>Set the Auto. A/Tone Switch to OFF, then feed in 15 kHz (-20 dB).</li> <li>Record signals on the reference SX tape (DA09025A), then play it back.</li> <li>Check to insure that the playback level is the same as the source monitor level for both channels.</li> <li>If above is insured, the Auto Azimuth Alignment function is accurate.</li> </ol> </li> </ol>

STEP	ITEM	SIGNAL SOURCE	OUTPUT CONNECTION	MODE	ADJUSTMENT	REMARKS
14	Record Level Calibration and Recording Bias Current Adjustment	Test Tone 400 Hz or 400 Hz and 15 kHz (-20 dB) to INPUT Jacks	VTVM and Distortion Meter to OUTPUT Jacks	Record, Playback Auto. A/Tone SW - CAL/OFF Tape SW - EX/SX/ZX Eq. SW - 120 $\mu$ s (EX) 70 $\mu$ s (SX/ZX) Dolby NR SW - OUT	Rec. Cal. P.C.B. (Level) ZX: VR701, VR801 SX: VR702, VR802 EX: VR703, VR803  Switch P.C.B. (Bias) ZX: VR101, VR201 SX: VR102, VR202 EX: VR103, VR203	For each tape to be used, perform the Auto Azimuth Alignment operation by depressing Record and Play Buttons simultaneously after setting the Auto. A/Tone Switch to CAL. To minimize the influence of interference between each volume, adjustment should be made in the order of ZX, SX and EX.  1. Set the Auto. A/Tone Switch to CAL. 2. Record signals on the reference ZX tape (DA09037A), SX tape (DA09025A), or EXII tape (DA09021A), then play it back. 3. Adjust Record Cal. VR701 (VR801) (for ZX), VR702 (VR802) (for SX), or VR703 (VR803) (for EXII) to the center position. 4. Adjust Bias VR101 (VR201) (for ZX), VR102 (VR202) (for SX), or VR103 (VR203) (for EXII) to obtain maximum reading on the VTVM. 5. Set the Auto. A/Tone Switch to OFF, then feed in 15 kHz (-20 dB). 6. Adjust finely VR101 (VR201) (for ZX), VR102 (VR202) (for SX), or VR103 (VR203) (for EXII) to obtain the same reading as the source monitor level on the VTVM. 7. Set the Auto. A/Tone Switch to CAL. 8. Adjust Record Cal. VR701 (VR801) (for ZX), or VR702 (VR802) (for SX), or VR703 (VR803) (for EXII) to obtain 0 dB on the level meter. 9. Repeat 5 through 8 as above two or three times to obtain optimum performance. 10. Check whether the total harmonic distortion (T.H.D.) is less than 0.8% (for ZX), or 1.0% (for SX and EXII). Note: Typical bias current ZX: approx. 4.6 mA SX: approx. 2.5 mA EXII: approx. 1.6 mA
15	Overall Frequency Response	400 Hz (0 dB) and 20 Hz to 22 kHz/20 kHz (-20 dB) to INPUT Jacks	VTVM and Distortion Meter to OUTPUT Jacks	Record, Playback Auto. A/Tone SW - OFF Tape SW - EX/SX/ZX Eq. SW - 120 $\mu$ s (EX) 70 $\mu$ s (SX/ZX) Dolby NR SW - OUT	Main P.C.B. L104, L204	For each tape to be used, perform the Auto Azimuth Alignment operation by depressing Record and Play Buttons simultaneously after setting the Auto. A/Tone Switch to CAL.  1. Feed in 400 Hz (0 dB) and adjust input level controls to obtain 0 dB on the level meters. 2. Switch the Generator output level to -20 dB, then record and play it back. 3. Feed in 20 Hz to 22 kHz (-20 dB) (for ZX), or 20 Hz to 20 kHz (-20 dB) (for SX and EXII), and check to insure if the output levels are within -20 dB $\pm$ 3 dB. 4. If above is not sufficient, adjust L104 (L204) to obtain approx. -20 dB on the VTVM. 5. Conduct step 14 "Record Level Calibration and Recording Bias Current Adjustment". 6. If above is not sufficient, precise re-adjustment of step 8 "Playback Frequency Response", replacement of Playback Head or Record Head, or check on item 4.10 "Tape Travelling Adjustment" will be required.
16	Crosstalk	1 kHz to INPUT Jacks	1 kHz Band Pass Filter and VTVM to OUTPUT Jacks	Record and Playback Auto. A/Tone SW - OFF Tape SW - ZX Eq. SW - 70 $\mu$ s Dolby NR SW - OUT		1. Erase the tape with bulk eraser. 2. Adjust input level controls to obtain 0 dB on the level meters, and record the signals on the reference tape. 3. Turn the cassette tape the other way round and play it back. 4. Measure the difference between 2 and 3.
17	Channel Separation	1 kHz to INPUT Jacks	Same as above	Same as above		1. Erase the tape with bulk eraser. 2. Adjust Lch (Rch) input level control to obtain 0 dB on the level meters, and close Rch (Lch) input level control. 3. Record and play it back, then measure the Rch (Lch) level.

STEP	ITEM	SIGNAL SOURCE	OUTPUT CONNECTION	MODE	ADJUSTMENT	REMARKS
18	Erasure	1 kHz to INPUT Jacks	1 kHz Band Pass Filter and VTVM to OUTPUT Jacks	Record and Playback Auto. A/Tone SW – OFF Tape SW – ZX Eq. SW – 70 $\mu$ s Dolby NR SW – OUT		<ol style="list-style-type: none"> <li>Erase the tape with bulk eraser.</li> <li>Adjust input level controls to obtain 0 dB on the level meters, and record the signals on the reference tape.</li> <li>Rewind the tape then close input level controls.</li> <li>Record and play it back, then measure the difference between 2 and 3.</li> </ol>
19	Signal to Noise Ratio	400 Hz to INPUT Jacks	VTVM and Distortion Meter to OUTPUT Jacks	Record and Playback Monitor SW – Tape Auto. A/Tone SW – OFF Tape SW – ZX Eq. SW – 70 $\mu$ s Dolby NR SW – MPX		<ol style="list-style-type: none"> <li>Feed in 400 Hz and record, and play it back.</li> <li>Adjust the input level controls to obtain 3% total harmonic distortion in playback mode.</li> <li>Close the input level controls then record.</li> <li>After rewind, play back and check the output level difference between 2 and 3.</li> </ol> <p>Note: The filter of IHF-A curve shall be used in the measurements.</p>
20	Total Harmonic Distortion	400 Hz to INPUT Jacks	Distortion Meter to OUTPUT Jacks	Record and Playback Auto. A/Tone SW – OFF Tape SW – EX/SX/ZX Eq. SW – 120 $\mu$ s (EX) 70 $\mu$ s (SX/ZX) Dolby NR SW – OUT		<ol style="list-style-type: none"> <li>Adjust input level controls to obtain 0 dB on the level meters.</li> <li>Record and play it back.</li> <li>Read the distortion meter and check to insure that the distortion is less than 0.8% for ZX tape and 1.0% for SX and EXII tapes.</li> </ol>
21	Wow/Flutter	3 kHz Speed and Wow/Flutter Tape (DA09006A)	Wow/Flutter Meter to OUTPUT Jacks	Playback Monitor SW – Tape Auto. A/Tone SW – OFF Eq. SW - 70 $\mu$ s Dolby NR SW – OUT		Play back and read the wow/flutter meter.

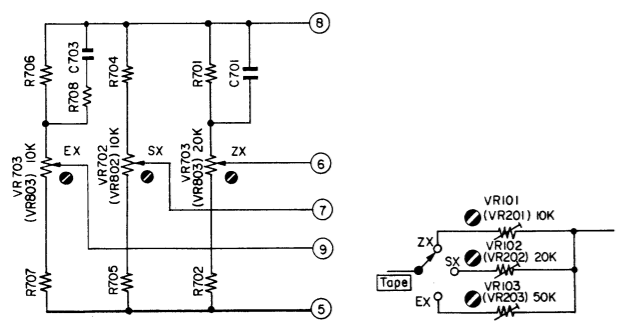

Fig. 6.11 14. Recording Level and Bias Current

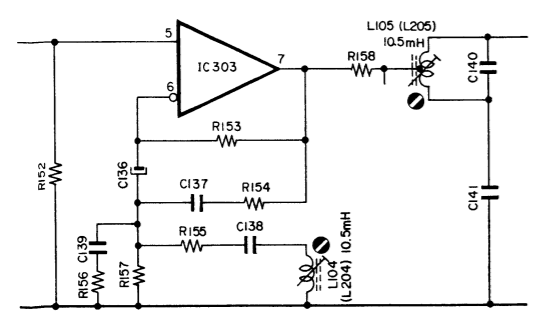

Fig. 6.12 15. Overall Frequency Response

6.2. Frequency Response Adjustment

(1) Playback Frequency Response Adjustment

Refer to Figs. 6.13 and 6.14.

(a) Level Adjustment (for middle frequency response)

This adjustment will be required when playback level is not sufficient at 10 kHz PB Frequency Response Tape (refer to step 8 in "6.1. Adjustment and Measurement Instructions").

Playback equalization level can be varied by the modification of R130 (R230) and R131 (R231).

Following are the details for level modification:

Approx. +1 dB	R131 (R231): 3.0K
	R130 (R230): 4.3K
0 dB	R131 (R231): 3.3K
	R130 (R230): 4.7K
Approx. -1 dB	R131 (R231): 3.6K
	R130 (R230): 5.1K

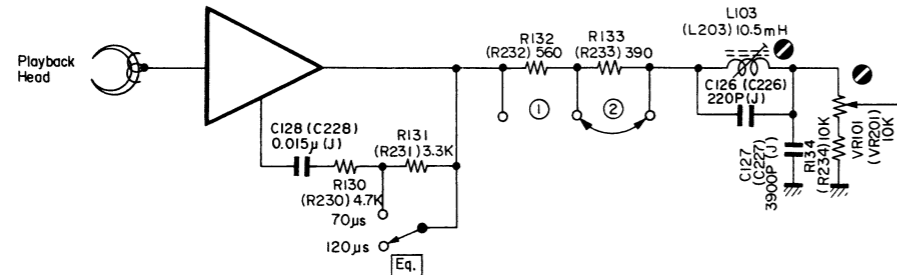

Fig. 6.14 Playback Eq. Amp.

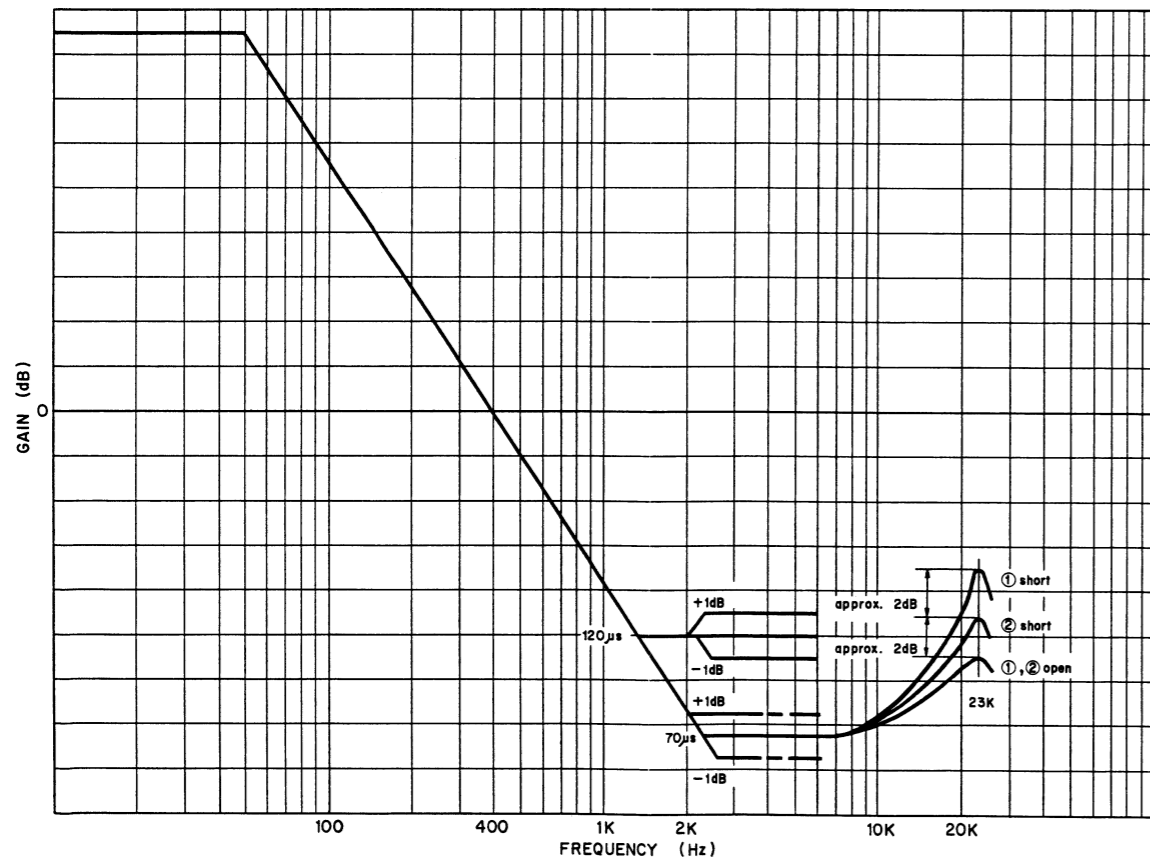

Fig. 6.13 Playback Equalization Curve

(b) Peaking Adjustment (for high frequency response)

This adjustment will be required when playback level is not sufficient at 20 kHz PB Frequency Response Tape (refer to step 8 in "6.1. Adjustment and Measurement Instructions").

Peaking portion compensates the gap loss of the playback head.

Peaking level is varied by the short circuit of R132 (R232) or R133 (R233) as illustrated in the figure.

(2) Record Current Frequency Response Adjustment

Record eq. peaking is adjusted for compensating the overall frequency response when playback frequency response is completed.

Normally however peaking frequency is pre-adjusted to approx. 23 kHz in record mode. See Fig. 6.15.

(a) For ZX Tape

1) Feed in 400 Hz (0 dB), then record and play it back.

Adjust bias current by VR101 (VR201) on the Switch P.C.B. to obtain a 0.8% distortion.

2) Feed in 10 kHz and 400 Hz (-20 dB), then record and play it back.

Check the difference of the levels between 10 kHz and 400 Hz, and mount an additional capacitor in parallel with the C118 (C218) on the Main P.C.B. from the dip side of the printed circuit board depending upon the difference of the levels against 400 Hz. See Fig. 6.16.

	Add	Total
0 dB	0	680 pF
-1 dB	330 pF	1010 pF
-2 dB	680 pF	1360 pF

3) Feed in 22 kHz (-20 dB), then record and play it back.

Adjust record peaking coil L104 (L204) to obtain flat overall frequency response.

(b) For SX Tape

1) Feed in 15 kHz and 400 Hz (-20 dB), then record and play it back.

Adjust bias current by VR102 (VR202) on the Switch P.C.B. to obtain flat overall frequency response.

2) Feed in 20 kHz and 400 Hz (-20 dB), then record and play it back.

And check to insure that the overall frequency response is flat.

(c) For EX Tape

1) Feed in 15 kHz and 400 Hz (-20 dB), then record and play it back.

Adjust bias current by VR103 (VR203) on the Switch P.C.B. to obtain flat overall frequency response.

2) Feed in 20 kHz and 400 Hz (-20 dB), then record and play it back.

And check to insure that the overall frequency response is flat.

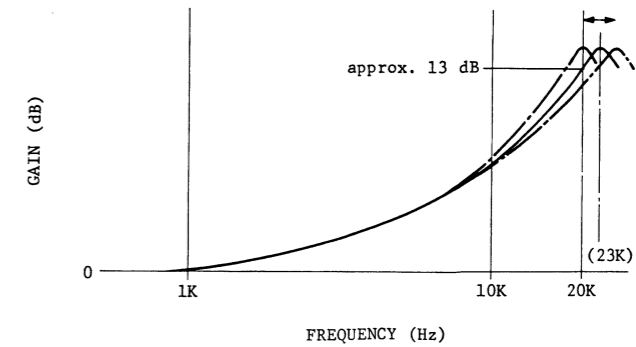

Fig. 6.15 Record Peaking Curve

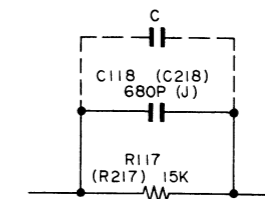

Fig. 6.16

7. MOUNTING DIAGRAMS

Note: Mounting diagram shows a dip side view of the printed circuit board.

7.1. Control Switch P.C.B. Ass'y

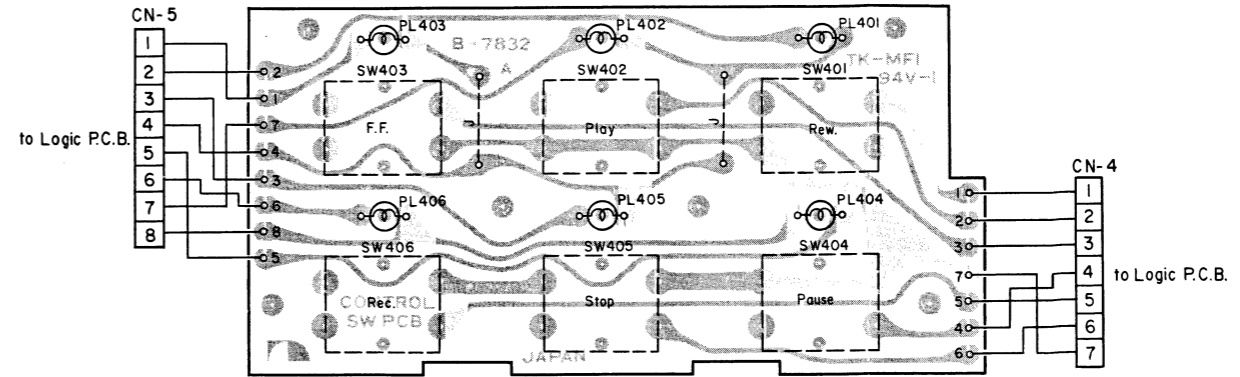

Fig. 7.1

7.2. Lamp P.C.B. B Ass'y

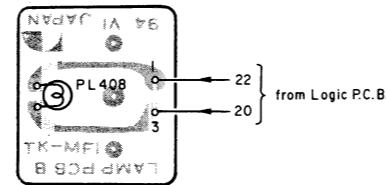

Fig. 7.2

7.3. Lamp P.C.B. C Ass'y

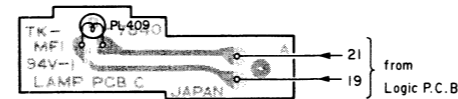

Fig. 7.3

7.4. RAMM P.C.B. Ass'y

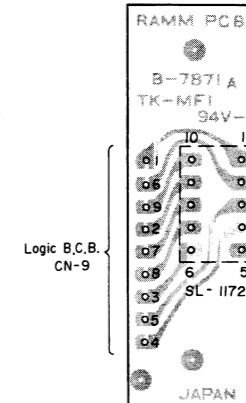

Fig. 7.4

6.3. Dolby NR Circuit Check

Dolby NR circuit incorporates a Dolby B-Type NR IC ( $\mu$ A7300PC) which has no adjustment point.

Perform the following checks and make sure that the IC operates accurately i.e., frequency response through IC is accurate.

- Signal Source: 5 kHz to INPUT Jacks
- Output Connection: VTVM to the output side of C117 (C217) on the Main P.C.B.
- Mode: Record, Pause  
MPX SW - IN

- (1) Remove the Bias-cut Jumper from the dip side of the Main P.C.B.
- (2) Connect a VTVM to TP101 (TP201) on the Main P.C.B.  
Feed in 5 kHz and adjust the input level so that the VTVM may read 100 mV (0 dB) at each test point. Pointer on the meter will indicate 0 dB.
- (3) Remove the VTVM from TP101 (TP201) and reconnect it to the output side of C117 (C217). Check to insure that the VTVM indicates approx. 560 mV.
- (4) Decrease the input level (0 dB) by 20 dB or 30 dB. Check to insure that the level at output side of C117 (C217) corresponds to the following with the Dolby NR Switch IN and OUT.
- (5) After completion of the adjustment, reconnect the Bias-cut Jumper.

Input Level (f=5 kHz)	Capacitor Output Level		
	Dolby NR OUT	Dolby NR IN	Difference between IN and OUT
-20 dB	-20 dB	-16.8 dB $\pm$ 1.5 dB	3.2 dB $\pm$ 1.5 dB
-30 dB	-30 dB	-21.8 dB $\pm$ 1.5 dB	8.2 dB $\pm$ 1.5 dB

Schematic Ref. No.	Part No.	Description	Schematic Ref. No.	Part No.	Description
SW401-406 PL401-406 CN4 CN5	BA04071A	Control Switch P.C.B. Ass'y	CN9	BA04209A	RAMM P.C.B. Ass'y
	0B07832A	Control Switch P.C.B.		0B07871A	RAMM P.C.B.
	0B07219A	Semi-switch		0B08712A	9P-H Connector Ass'y
	0B08552A	Lamp 12V 25mA		0B06246A	Segment LED (1 pce.)
	0B08631B	7P-H Connector A Ass'y			
PL408	BA04062A	Lamp P.C.B. B Ass'y			
	0B07838A	Lamp P.C.B. B			
PL409	0B08586A	Lamp 12V 60mA			
	BA04063A	Lamp P.C.B. C Ass'y			
	0B07840A	Lamp P.C.B. C			
	0B08586A	Lamp 12V 60mA			

Schematic Ref. No.	Part No.	Description
F1 M2	<b>BA04202A</b>	<b>Fuse P.C.B. Ass'y (U.S.A. &amp; Canada)</b>
	OB07842A	Fuse P.C.B.
	OB08374A	Fuse 1A 250V
	OB08342A	Spark Killer
	OM04075A	Fuse Caution A112 (1 pce.)
	OM03782A	Fuse Label 1A (1 pce.)
	OJ03834B	Fuse P.C.B. Holder (1 pce.)
OE00606A	Screw M3x6 Philips Pan Head (3A) (2 pcs.)	
OE00752A	Eyelet (6 pcs.)	
F1 M2	<b>BA04203A</b>	<b>Fuse P.C.B. Ass'y (Japan)</b>
	OB07842A	Fuse P.C.B.
	OB08686A	Fuse 1A 250V
	OB08363A	Spark Killer
	OM03782A	Fuse Label 1A (1 pce.)
	OJ03834B	Fuse P.C.B. Holder (1 pce.)
	OE00606A	Screw M3x6 Philips Pan Head (3A) (2 pcs.)
OE00752A	Eyelet (6 pcs.)	
F1 F4,5 M2	<b>BA04206A</b>	<b>Fuse P.C.B. Ass'y (Others)</b>
	OB07842A	Fuse P.C.B.
	OB08263A	Fuse T 315mA 250V
	OB08161A	Fuse T 630mA 250V
	OB08240A	Spark Killer
	OB08349A	Fuse Clip (4 pcs.)
	OM04073A	Fuse Label 315mA (1 pce.)
	OM04072A	Fuse Label 630mA x2 (1 pce.)
	OJ03834B	Fuse P.C.B. Holder (1 pce.)
	OE00606A	Screw M3x6 Philips Pan Head (3A) (2 pcs.)
OE00752A	Eyelet (6 pcs.)	
F1 F4,5 M2	<b>BA04205A</b>	<b>Fuse P.C.B. Ass'y (UK &amp; Australia)</b>
	OB07842A	Fuse P.C.B.
	OB08665A	Fuse T 160mA 250V
	OB08161U	Fuse T 630mA 250V
	OB08240A	Spark Killer
	OB08349A	Fuse Clip (6 pcs.)
	OM04066A	Fuse Label 160mA (1 pce.)
	OM04072A	Fuse Label 630mA x2 (1 pce.)
	OJ03834B	Fuse P.C.B. Holder (1 pce.)
	OE00606A	Screw M3x6 Philips Pan Head (3A) (2 pcs.)
OE00752A	Eyelet (6 pcs.)	
F1 F4,5 M2,3	<b>BA04204A</b>	<b>Fuse P.C.B. Ass'y (220V Class 2)</b>
	OB07842A	Fuse P.C.B.
	OB08665A	Fuse T160mA 250V
	OB08161U	Fuse T630mA 250V
	OB08445A	Spark Killer
	OB08349A	Fuse Clip (6 pcs.)
	OM04066A	Fuse Label 160mA (1 pce.)
	OM04072A	Fuse Label 630mA x 2 (1 pce.)
	OJ03834B	Fuse P.C.B. Holder (1 pce.)
	OE00606A	Screw M3x6 Philips Pan Head (3A) (2 pcs.)
OE00752A	Eyelet (6 pcs.)	

7.5. Fuse P.C.B. Ass'y

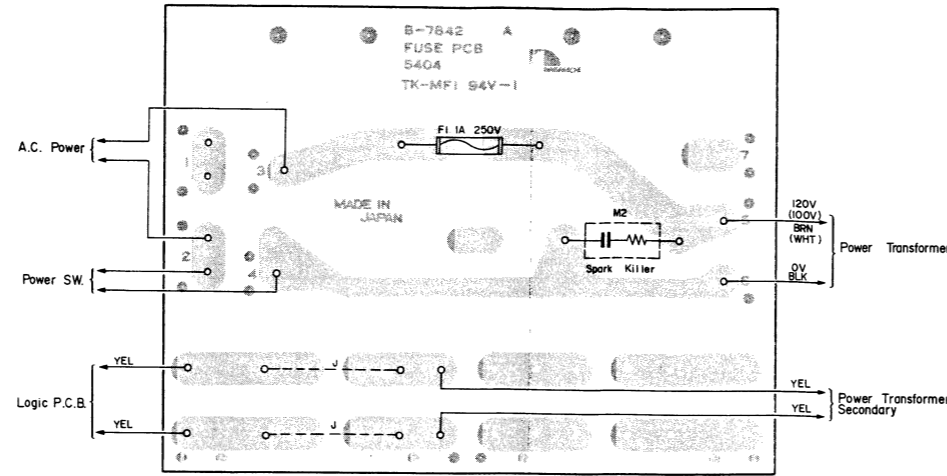

Fig. 7.5.1 U.S.A., Canada and Japan

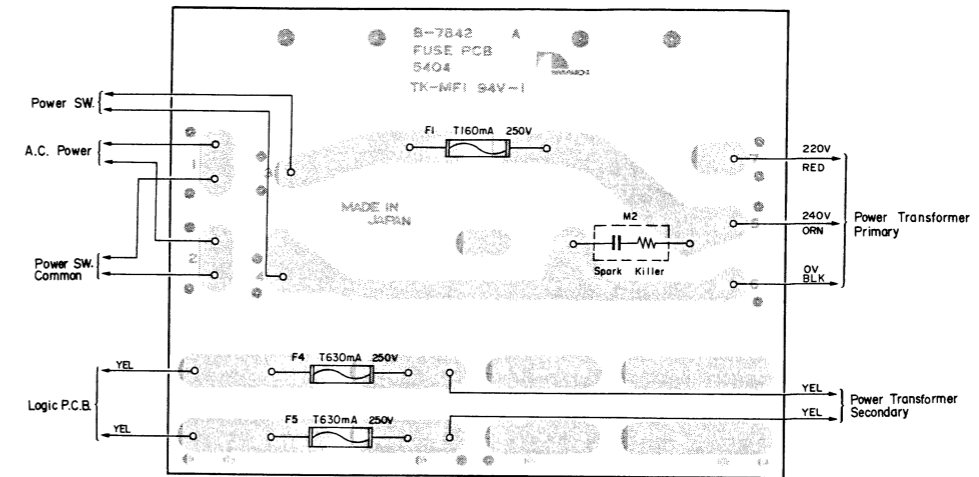

Fig. 7.5.3 UK and Australia

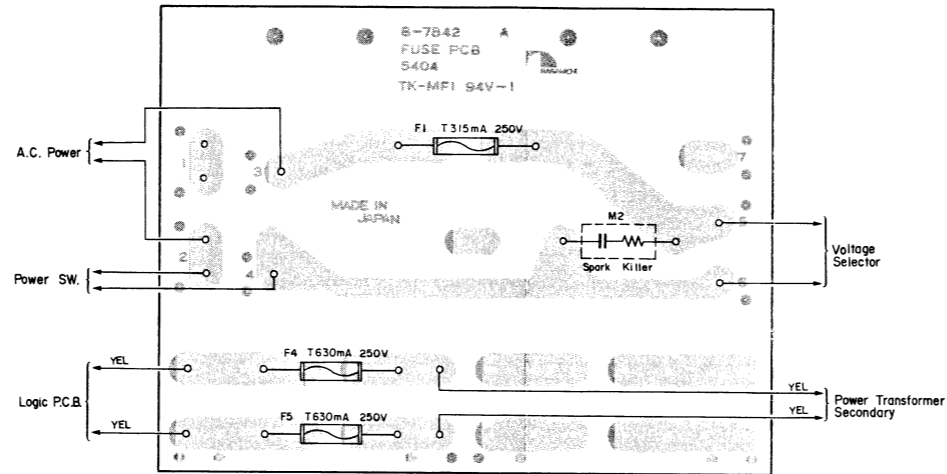

Fig. 7.5.2 Others

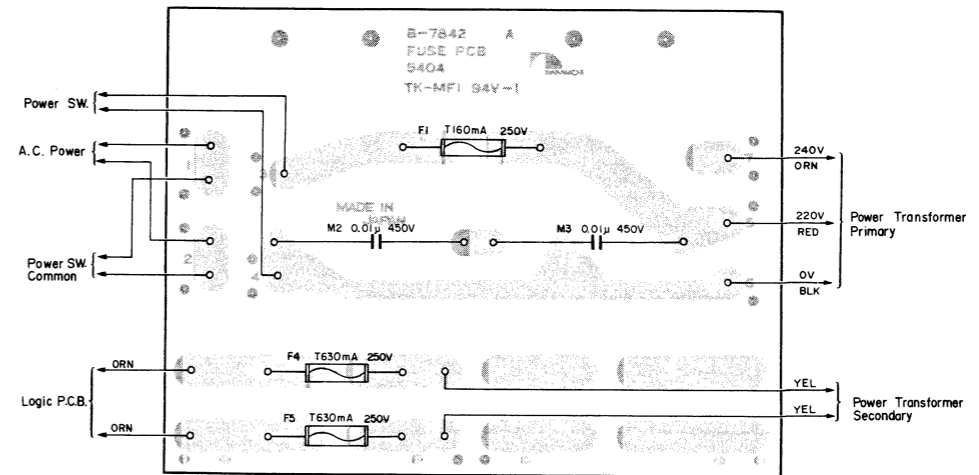

Fig. 7.5.4 220 V Class 2

Schematic Ref. No.	Part No.	Description	Schematic Ref. No.	Part No.	Description
	<b>BA04207A</b>	<b>Auto Azimuth P.C.B. Ass'y</b>		<b>BA04176A</b>	<b>Pin Jack P.C.B. Ass'y</b>
	OB07872A	Auto Azimuth P.C.B.		OB07835A	Pin Jack P.C.B.
IC901,905	OB06124B	IC $\mu$ PC4558C	FC5	OB05238A	5P Flat Cable 50mm
IC902	OB06216A	IC RC4556D		OB08709A	Jack Unit (1 pce.)
IC903	OB06213A	IC TC4013BP		OE00037A	Earth Lug B-5 (1 pce.)
IC904	OB06244A	IC TC4073BP			
Q901,902	OB01872A	Transistor 2SC945 (L)		<b>BA04070A</b>	<b>Auto Shut-off P.C.B. Ass'y</b>
905,906				OB07839A	Auto Shut-off P.C.B.
907,909			Q449	OB01872A	Transistor 2SC945 (L)
910			Q450	OB06228A	Photo Transistor PH104
Q903	OB06066A	Transistor 2SD471	D470	OB06181A	Silicon Diode 1SS53
Q904	OB06069A	Transistor 2SB564	R603	OB05671A	Carbon Resistor 2.2M ERD-25T J
Q908	OB06013A	Transistor 2SA733	R604	OB05615A	Carbon Resistor 22K ERD-25T J
D701,702	OB06181A	Silicon Diode 1SS53 (10 pcs.)	R605	OB09215A	Fail Safe Type Resistor 100 RDF-25S J
801,802			R606	OB01888A	Carbon Resistor 10K ERD-25T J
901,905			C453	OB01405A	Electrolytic Capacitor 1 $\mu$ 50V
909			PL407	OB08552A	Lamp 12V 25mA
VR901	OB09107A	Semi-fixed Volume 500K			
R701,801	OB05625A	Carbon Resistor 220K ERD-25T J			
917,919					
R702,802	OB01889A	Carbon Resistor 100K ERD-25T J			
929,930					
R703,803	OB05576A	Carbon Resistor 470 ERD-25T J			
R704,804	OB05627A	Carbon Resistor 330K ERD-25T J			
904,927					
R705,706	OB05509A	Carbon Resistor 33K ERD-25T J			
805,806					
905,906					
907,909					
910,925					
R707,807	OB05671A	Carbon Resistor 2.2M ERD-25T J			
920,923					
928					
R901,902	OB05776A	Carbon Resistor 1M ERD-25T J			
903,918					
R908	OB01681A	Carbon Resistor 3.3K ERD-25T J			
R911,912	OB01887A	Carbon Resistor 5.6K ERD-25T J			
R913,922	OB01888A	Carbon Resistor 10K ERD-25T J			
R914,916	OB05615A	Carbon Resistor 22K ERD-25T J			
924,931					
R915	OB09380A	Carbon Resistor 1.5M ERD-25T J			
R921	OB05692A	Carbon Resistor 68K ERD-25T J			
R926	OB01682A	Carbon Resistor 6.8K ERD-25T J			
R932	OB05626A	Carbon Resistor 150K ERD-25T J			
R933	OB05641A	Carbon Resistor 47K ERD-25T J			
C701,801	OB01405A	Electrolytic Capacitor 1 $\mu$ 50V			
901,902					
C702,802	OB01412A	Electrolytic Capacitor 10 $\mu$ 16V			
C704,804	OB01802A	Mylar Capacitor 2200P 50V J			
C705,805	OB01676A	Mylar Capacitor 0.056 $\mu$ 50V			
C903	OB09372A	Electrolytic Capacitor 2.2 $\mu$ 25V			
C904	OB05772A	Tantalum Capacitor 0.22 $\mu$ 35V			
CN 10	OB08656A	2P-T Post			

7.6. Auto Azimuth P.C.B. Ass'y

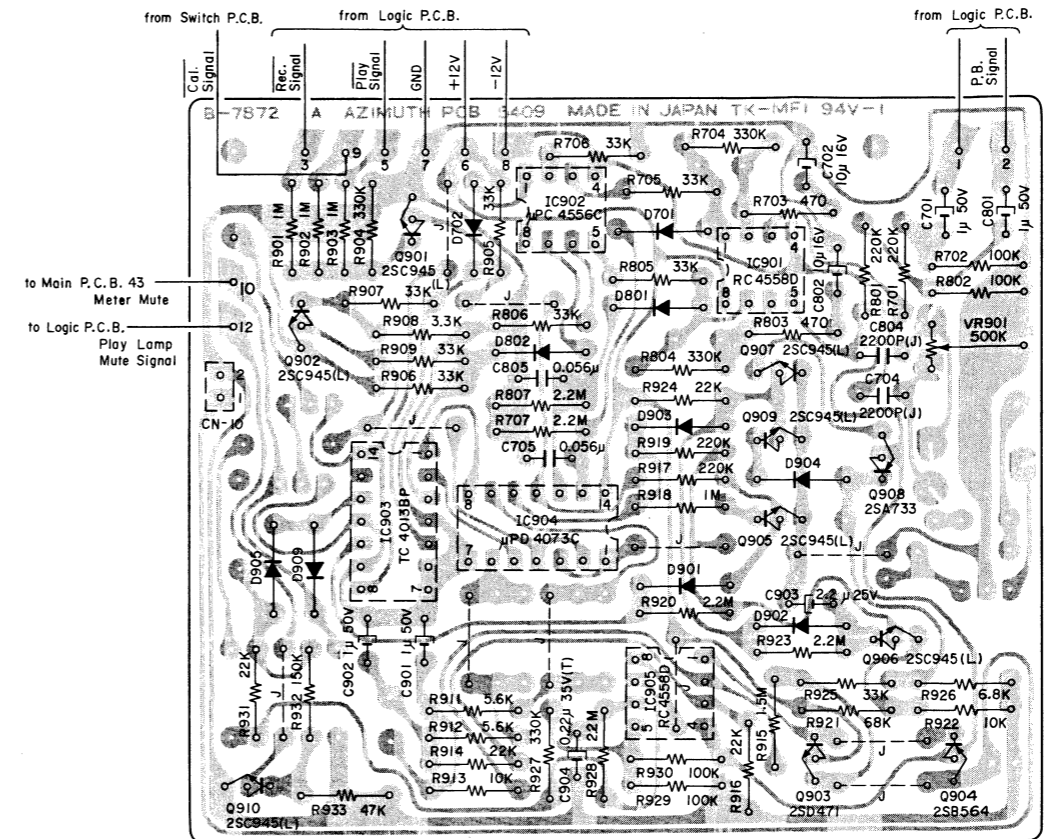

Fig. 7.6 Note: Diode is 1SS53 unless otherwise specified.

7.7. Pin Jack P.C.B. Ass'y

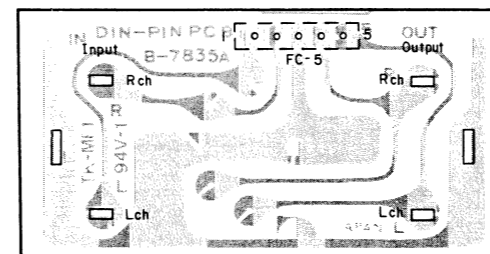

Fig. 7.7

7.8. Auto Shut-off P.C.B. Ass'y

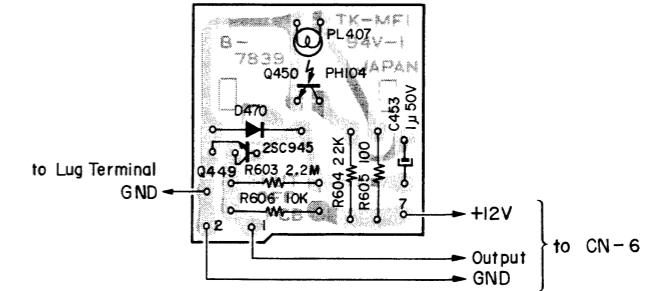

Fig. 7.8

Note: Diode is 1SS53 unless otherwise specified.

7.9. Switch P.C.B. Ass'y

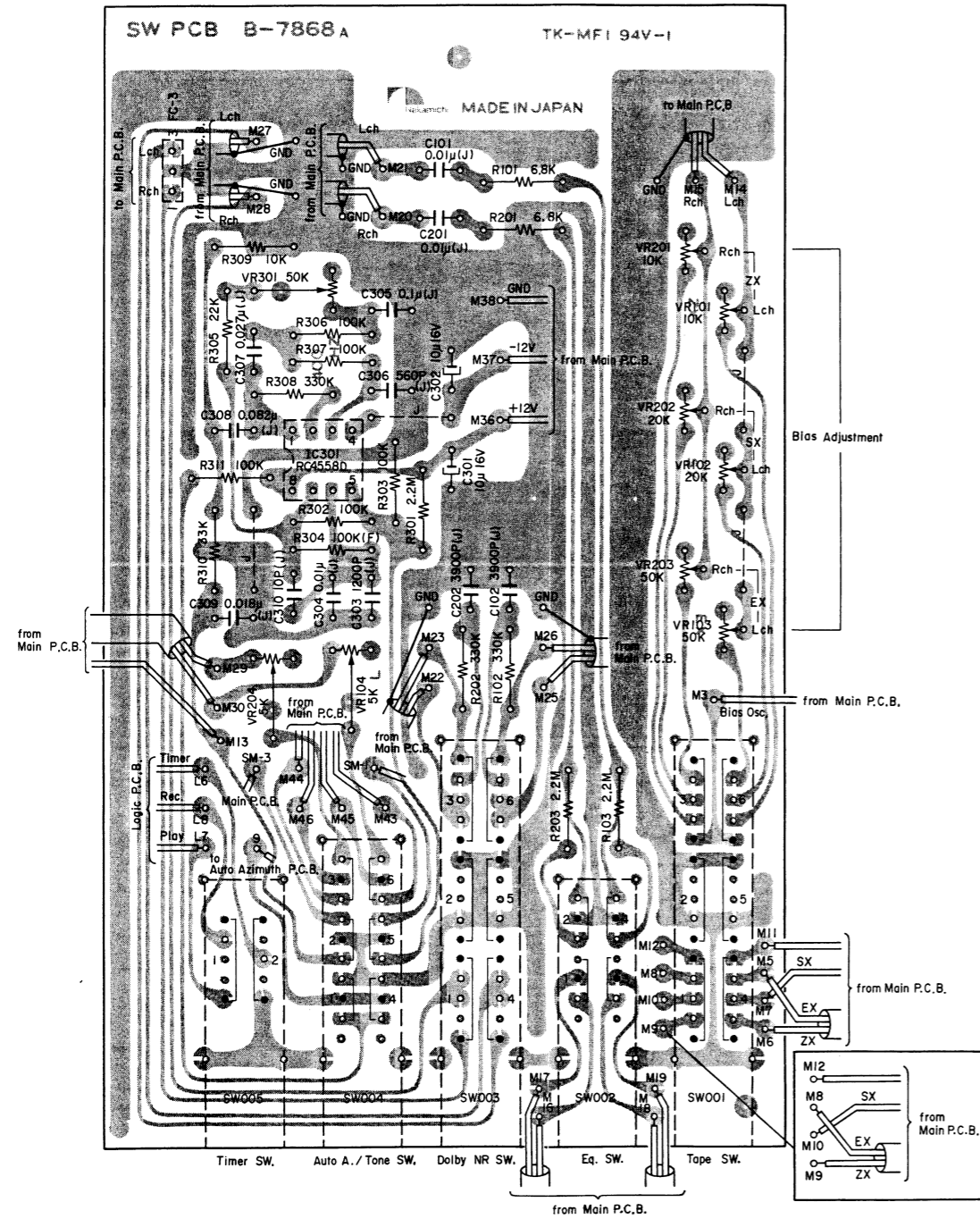

Fig. 7.9 Note: Diode is 1SS53 unless otherwise specified.

7.10. Record Cal. P.C.B. Ass'y

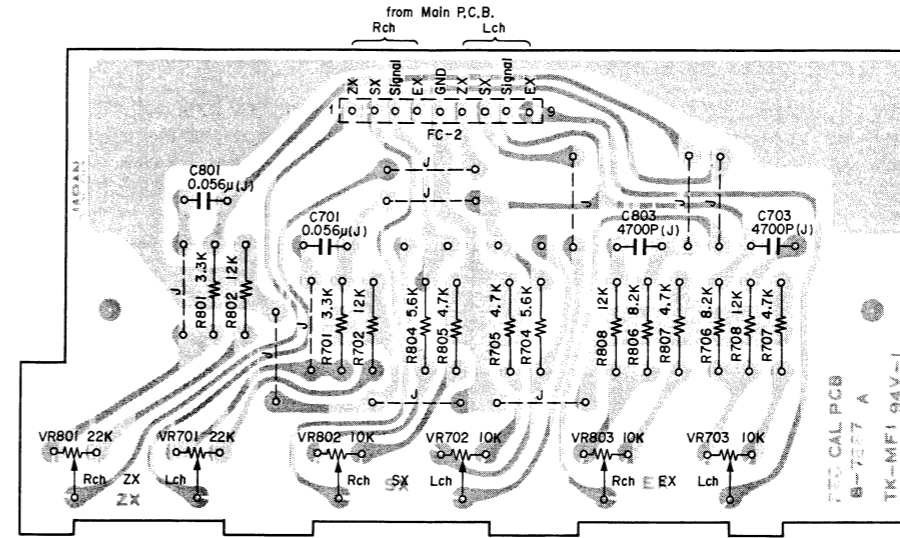

Fig. 7.10

7.11. Volume P.C.B. Ass'y

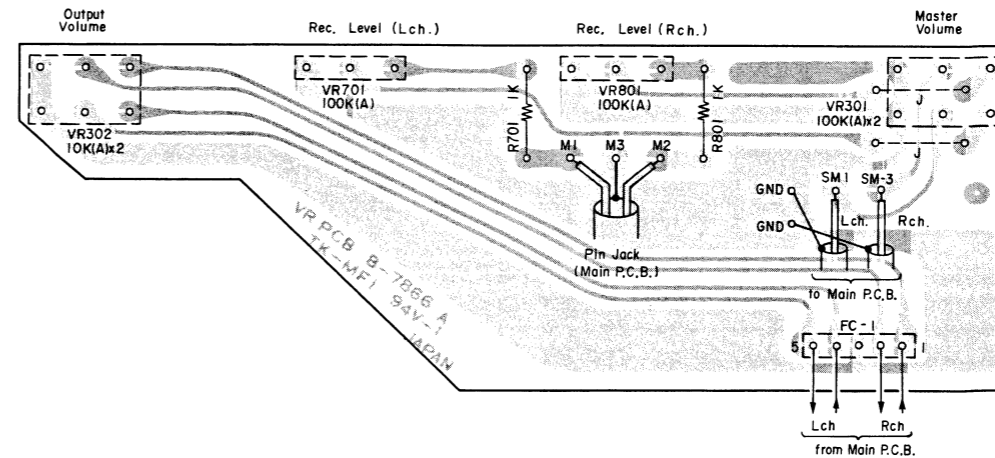

Fig. 7.11



Schematic Ref. No.	Part No.	Description	Schematic Ref. No.	Part No.	Description
	<b>BA04190A</b>	<b>Switch P.C.B. Ass'y</b>		<b>BA04188A</b>	<b>Record Cal. P.C.B. Ass'y</b>
		<b>— Tone Osc. —</b>			
IC301	0B06124B	IC RC4558D	VR701,801	0B07867A	Record Cal. P.C.B.
VR301	0B07237A	Semi-fixed Volume 50K	VR702,703	0B07276A	Semi-fixed Volume 22K
R301	0B05671A	Carbon Resistor 2.2M ERD-25T J	802,803	0B07319A	Semi-fixed Volume 10K
R302,303	0B01889A	Carbon Resistor 100K ERD-25T J	R701,801	0B01681A	Carbon Resistor 3.3K ERD-25T J
306,307			R702,708	0B09263A	Carbon Resistor 12K ERD-25T J
R304	0B09305A	Metal Film Resistor 100K SN14K2E F	802,808		
R305	0B05615A	Carbon Resistor 22K ERD-25T J	R704,804	0B01887A	Carbon Resistor 5.6K ERD-25T J
R308	0B05627A	Carbon Resistor 330K ERD-25T J	R705,707	0B01846A	Carbon Resistor 4.7K ERD-25T J
R309	0B01888A	Carbon Resistor 10K ERD-25T J	805,807		
R310	0B05509A	Carbon Resistor 33K ERD-25T J	R706,806	0B01856A	Carbon Resistor 8.2K ERD-25T J
C301,302	0B01412A	Electrolytic Capacitor 10μ 16V	C701,801	0B05813A	Mylar Capacitor 0.056μ 50V J
C303	0B05687A	Mylar Capacitor 1200P 50V J	C703,803	0B05652A	Mylar Capacitor 4700P 50V J
C304	0B05681A	Mylar Capacitor 0.01μ 50V J	FC2	0B05245A	9P Flat Cable 90mm
C305	0B01780A	Mylar Capacitor 0.1μ 50V J			
C306	0B09323A	PP Capacitor 560P 100V J		<b>BA04175A</b>	<b>Volume P.C.B. Ass'y</b>
C307	0B09045A	Mylar Capacitor 0.027μ 50V J			
C308	0B05685A	Mylar Capacitor 0.082μ 50V J	VR301	0B07866A	Volume P.C.B.
C309	0B05832A	Mylar Capacitor 0.018μ 50V J	VR302	0B07203A	Volume 100K (A) x 2
C310	0B09277A	Ceramic Capacitor 10P 50V J	VR701,801	0B07204A	Volume 10K (A) x 2
		<b>— Miscellaneous —</b>	R701,801	0B07202A	Volume 100K (A)
			FC1	0B01857A	Carbon Resistor 1K ERD-25T J
VR101,201	0B07868A	Switch P.C.B.		0B05238A	5P Flat Cable 50mm
VR102,202	0B07162A	Semi-fixed Volume 10K			
VR103,203	0B07215A	Semi-fixed Volume 20K			
VR104,204	0B07058A	Semi-fixed Volume 50K			
R101,201	0B03831A	Semi-fixed Volume 5K			
R102,202	0B01682A	Carbon Resistor 6.8K ERD-25T J			
R103,203	0B05627A	Carbon Resistor 330K ERD-25T J			
R311	0B05671A	Carbon Resistor 2.2M ERD-25T J			
C101,201	0B01889A	Carbon Resistor 100K ERD-25T J			
C102,202	0B05681A	Mylar Capacitor 0.01μ 50V J			
SW001,003	0B01804A	Mylar Capacitor 3900P 50V J			
SW002	0B07304A	Lever Switch 6-3S			
SW004	0B07285A	Lever Switch 4-2S			
SW005	0B07320A	Lever Switch 6-2S			
FC3	0B07284A	Lever Switch 2-3S			
	0B05240A	3P Flat Cable 50mm			

7.12. Main P.C.B. Ass'y

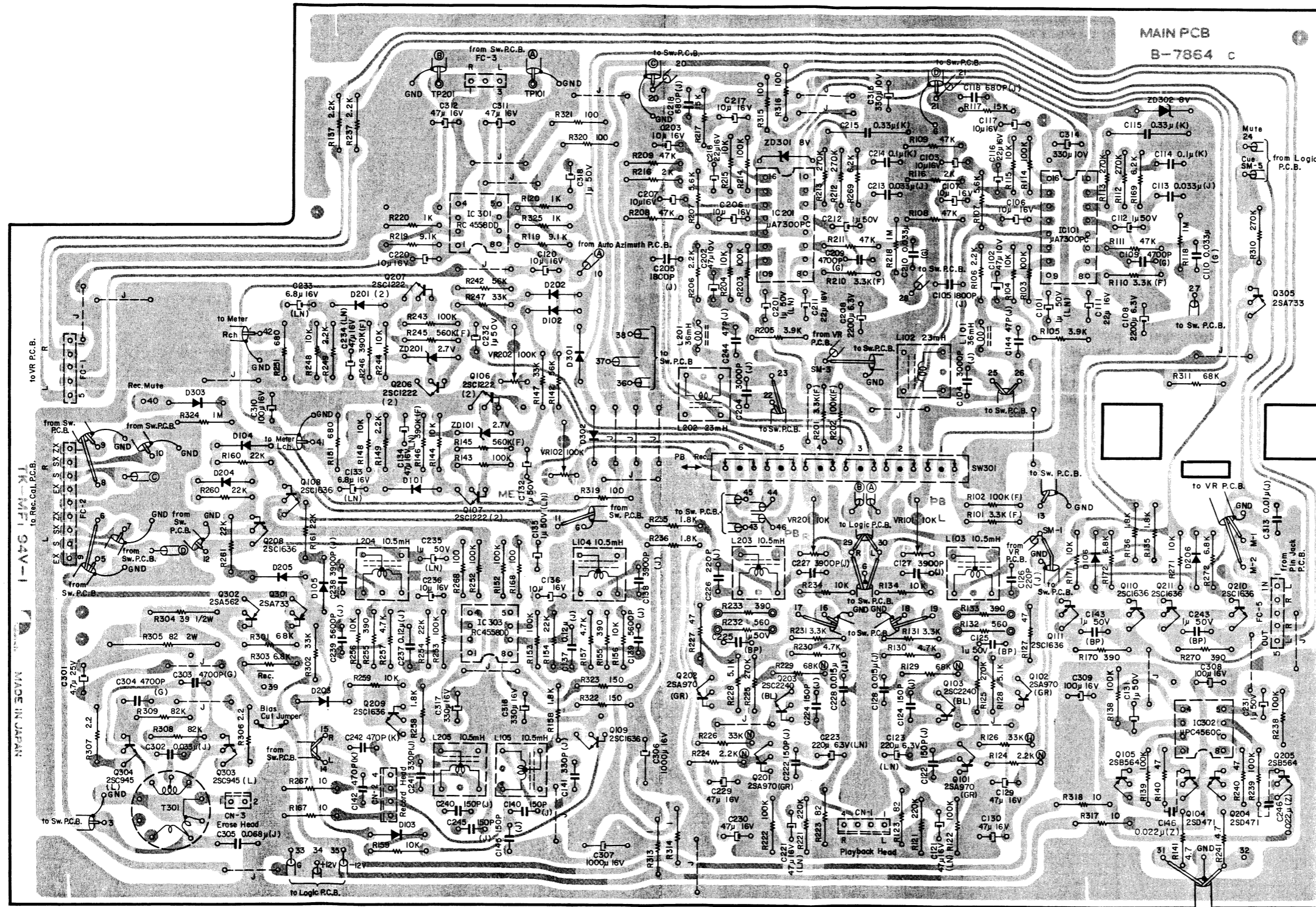

Fig. 7.12

Note: Diode is 1SS53 unless otherwise specified.



7.13. Logic P.C.B. Ass'y

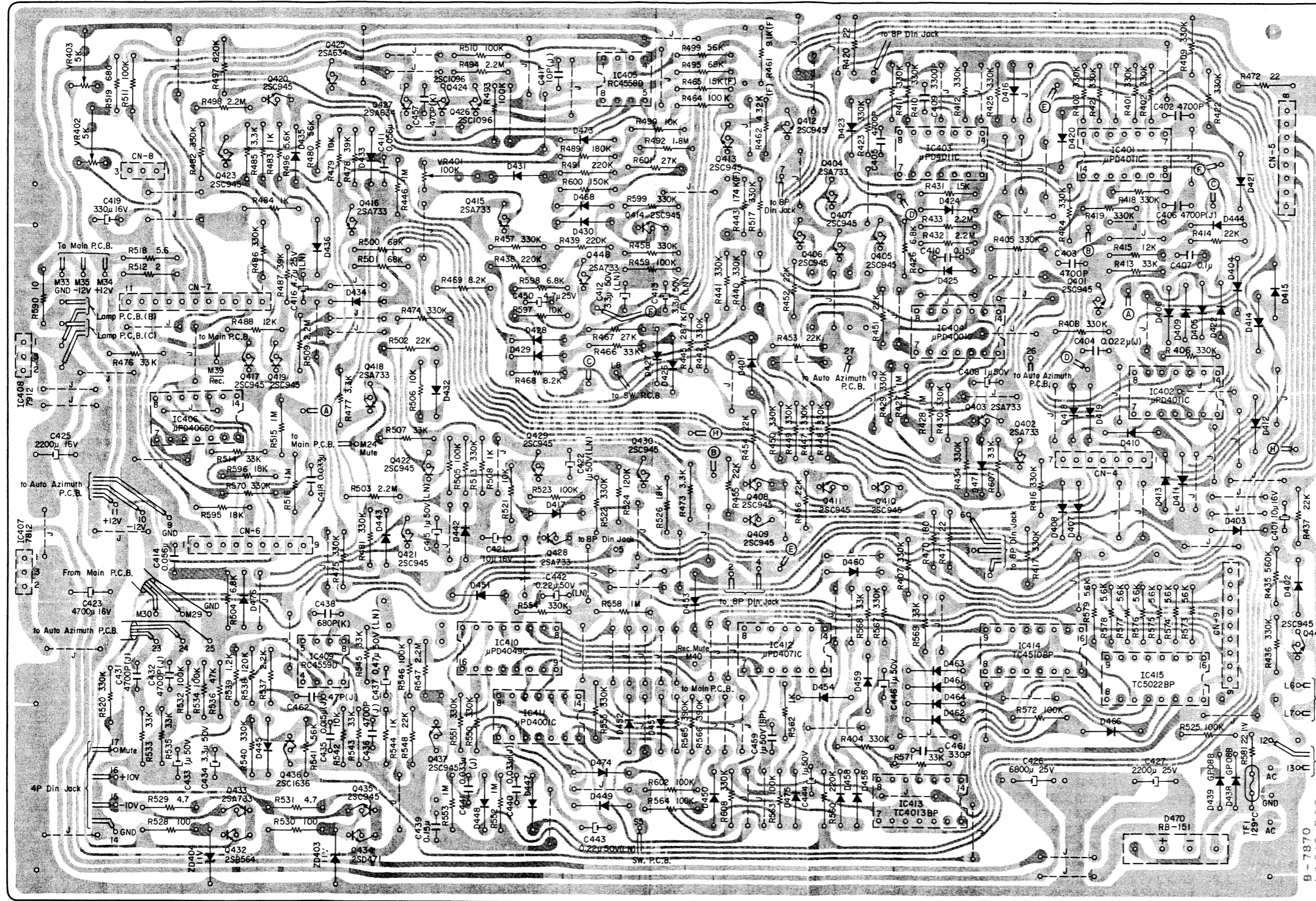

Fig. 7.13

Note: Diode is 1SS53 unless otherwise specified.

Schematic Ref. No.	Part No.	Description	Schematic Ref. No.	Part No.	Description	Schematic Ref. No.	Part No.	Description	Schematic Ref. No.	Part No.	Description
	BA04192A	Logic P.C.B. Ass'y	R431	OB05698A	Carbon Resistor 1.5K ERD-25T J	C426	OB09374A	Electrolytic Capacitor 6800µ 25V	C438	OB09287A	Ceramic Capacitor 680P 50V K
	- Logic -		R432,433	OB05671A	Carbon Resistor 2.2M ERD-25T J	C427	OB05654A	Electrolytic Capacitor 2200µ 25V	C439	OB00610A	Mylar Capacitor 0.15µ 50V
			494,498			C450	OB01402A	Electrolytic Capacitor 4.7µ 25V	C440,441	OB05583A	Mylar Capacitor 0.033µ 50V J
			503,509			C457	OB09286A	Ceramic Capacitor 470P 50V K	C442,443	OB09220A	Electrolytic Capacitor 0.22µ 50V (LN)
IC401,402	OB06178A	IC µPD4011C	R435	OB05784A	Carbon Resistor 560K ERD-25T J	CN4	OB08643A	7P-T Post	C459	OB09187A	Electrolytic Capacitor 1µ 50V (BP)
403			R438,439	OB05625A	Carbon Resistor 220K ERD-25T J	CN5	OB08644A	8P-T Post	C461	OB01180A	Ceramic Capacitor 330P 100V
IC404	OB06143A	IC µPD4001C	491			CN6,9	OB08645A	9P-T Post	C462	OB09280A	Ceramic Capacitor 47P 50V J
IC405	OB06124B	IC µPC4558C	R443	OB09367A	Metal Film Resistor 174K SN14K2E F	CN7	OB08655A	11P-T Post			
IC406	OB06144A	IC µPD4066C	R445	OB09366A	Metal Film Resistor 287K SN14K2E F	CN8	OB08653A	3P-T Post			
IC407	OB06192A	Regulator +12V µA7812	R459,464	OB01889A	Carbon Resistor 100K ERD-25T J	TF1	OB08715A	Thermal Fuse			
IC408	OB06193A	Regulator -12V µA7912	493,505								
Q401	OB06100A	Transistor 2SC945 (A) (21 pcs.)	510,511								
405-414			523,525								
417			R461	OB09328A	Metal Film Resistor 9.1K SN14K2E F	IC409	OB06127A	IC RC4559D			
419-423			R462	OB09365A	Metal Film Resistor 4.32K SN14K2E F	IC410	OB06250A	IC µPD4049C			
429,430			R465	OB09340A	Metal Film Resistor 15K SN64K2E F	IC411	OB06143A	IC µPD4001C			
435,447			R467,601	OB05743A	Carbon Resistor 27K ERD-25T J	IC412	OB06214A	IC µPD4071C			
Q402,403	OB06013A	Transistor 2SA733	R468,469	OB01856A	Carbon Resistor 8.2K ERD-25T J	IC413	OB06213A	IC TC4013BP			
404,415			R470	OB05578A	Carbon Resistor 180 ERD-25T J	IC414	OB06212	IC TC4510BP			
416,418			R473,477	OB01681A	Carbon Resistor 3.3K ERD-25T J	IC415	OB06211A	IC TC5022BP			
428,433			485			Q436	OB06070A	Transistor 2SC1636			
448			R478,487	OB01854A	Carbon Resistor 39K ERD-25T J	Q437	OB06100A	Transistor 2SC945 (A)			
Q424,426	OB06020A	Transistor 2SC1096	R479,490	OB01888A	Carbon Resistor 10K ERD-25T J	D445	OB06181A	Silicon Diode 1SS53			
Q425,427	OB06012A	Transistor 2SA634	506,521			447-454					
Q432	OB06069A	Transistor 2SB564	597			456-464					
Q434	OB06066A	Transistor 2SD471	R480,499	OB05508A	Carbon Resistor 56K ERD-25T J	466,474					
ZD403,404	OB06231A	Zener Diode RD11EB2	R483,484	OB01857A	Carbon Resistor 1K ERD-25T J	475					
D401-436	OB01909A	Silicon Diode 1S1555 (43 pcs.)	508			R532,534	OB01889A	Carbon Resistor 100K ERD-25T J			
442-444			R489	OB05640A	Carbon Resistor 180K ERD-25T J	546,563					
468,471			R492	OB05680A	Carbon Resistor 1.8M ERD-25T J	564,572					
473,476			R495,500	OB05692A	Carbon Resistor 68K ERD-25T J	602					
D438,439	OB06109A	Silicon Diode GP08B	501			R533,535	OB05509A	Carbon Resistor 33K ERD-25T J			
D470	OB06183A	Diode Bridge RB151	R496	OB01887A	Carbon Resistor 5.6K ERD-25T J	543,545					
VR401	OB03832A	Semi-fixed Volume 100K	R497	OB09320A	Carbon Resistor 820K ERD-25T J	568,569					
VR402,403	OB03831A	Semi-fixed Volume 5K	R512	OB09381A	Fail Safe Type Resistor 2 RDF-25S J	571					
R401-412	OB05627A	Carbon Resistor 330K ERD-25T J (45 pcs.)	R518	OB09217A	Fail Safe Type Resistor 5.6 RDF-25S J	R536	OB05641A	Carbon Resistor 47K ERD-25T J			
416-419			R519	OB05794A	Carbon Resistor 680 ERD-25T J	R537	OB05622A	Carbon Resistor 2.2K ERD-25T J			
421-425			R524	OB05621A	Carbon Resistor 120K ERD-25T J	R538	OB05621A	Carbon Resistor 120K ERD-25T J			
429,430			R526,595	OB05560A	Carbon Resistor 18K ERD-25T J	R539	OB05623A	Carbon Resistor 1.2K ERD-25T J			
434,436			596			R540,550	OB05627A	Carbon Resistor 330K ERD-25T J			
440-442			R528,530	OB09215A	Fail Safe Type Resistor 100 RDF-25S J	551,554					
447-450			R529,531	OB09321A	Fail Safe Type Resistor 4.7 RDF-25S J	555,567					
457,458			R581	OB09378A	Fail Safe Type Resistor 22 RSF-1B J	608					
474,475			R590	OB09216A	Fail Safe Type Resistor 10 RDF-25S J	R541	OB05508A	Carbon Resistor 56K ERD-25T J			
481,482			R600	OB05626A	Carbon Resistor 150K ERD-25T J	R542	OB01888A	Carbon Resistor 10K ERD-25T J			
486,513			C401,421	OB01412A	Electrolytic Capacitor 10µ 16V	R544,562	OB01857A	Carbon Resistor 1K ERD-25T J			
517,520			C402,403	OB05556A	Mylar Capacitor 4700P 50V	R547	OB05671A	Carbon Resistor 2.2M ERD-25T J			
522,570			405,406			R548	OB05615A	Carbon Resistor 22K ERD-25T J			
599			C404	OB05582A	Mylar Capacitor 0.022µ 50V J	R552,553	OB05776A	Carbon Resistor 1M ERD-25T J			
R413,466	OB05509A	Carbon Resistor 33K ERD-25T J	C407	OB00093A	Mylar Capacitor 0.1µ 50V	558					
476,507			C408	OB01405A	Electrolytic Capacitor 1µ 50V	R573,574	OB01887A	Carbon Resistor 5.6K ERD-25T J			
514,607			C409	OB09166A	Mylar Capacitor 3300P 50V	575,576					
R414,437	OB05615A	Carbon Resistor 22K ERD-25T J (9 pcs.)	C410	OB00610A	Mylar Capacitor 0.15µ 50V	577,578					
451-456			C411,414	OB01676A	Mylar Capacitor 0.056µ 50V	579					
502			C412,413	OB09324A	Electrolytic Capacitor 3.3µ 50V (LN)	R560	OB05625A	Carbon Resistor 220K ERD-25T J			
R415,488	OB09263A	Carbon Resistor 12K ERD-25T J	C415,422	OB09223A	Electrolytic Capacitor 1µ 50V (LN)	R565,566	OB05676A	Carbon Resistor 390K ERD-25T J			
R420,471	OB09049A	Fail Safe Type Resistor 22 ERD-14F J	C416	OB09173A	Electrolytic Capacitor 4.7µ 25V (LN)	C431,432	OB05652A	Mylar Capacitor 4700P 50V J			
472			C417	OB09277A	Ceramic Capacitor 10P 50V J	436					
R426,504	OB01682A	Carbon Resistor 6.8K ERD-25T J	C418	OB05513A	Mylar Capacitor 0.033µ 50V	C433,444	OB01405A	Electrolytic Capacitor 1µ 50V			
598			C419	OB01502A	Electrolytic Capacitor 330µ 16V	446					
R427,428	OB05776A	Carbon Resistor 1M ERD-25T J	C423	OB09377A	Electrolytic Capacitor 4700µ 16V	C434	OB01863A	Electrolytic Capacitor 3.3µ 50V			
446,515			C425	OB01406A	Electrolytic Capacitor 2200µ 16V	C435	OB05557A	Mylar Capacitor 0.015µ 50V J			
516						C437	OB09222A	Electrolytic Capacitor 0.47µ 50V (LN)			

8. MECHANISM ASS'Y AND PARTS LIST

8.1. Synthesis

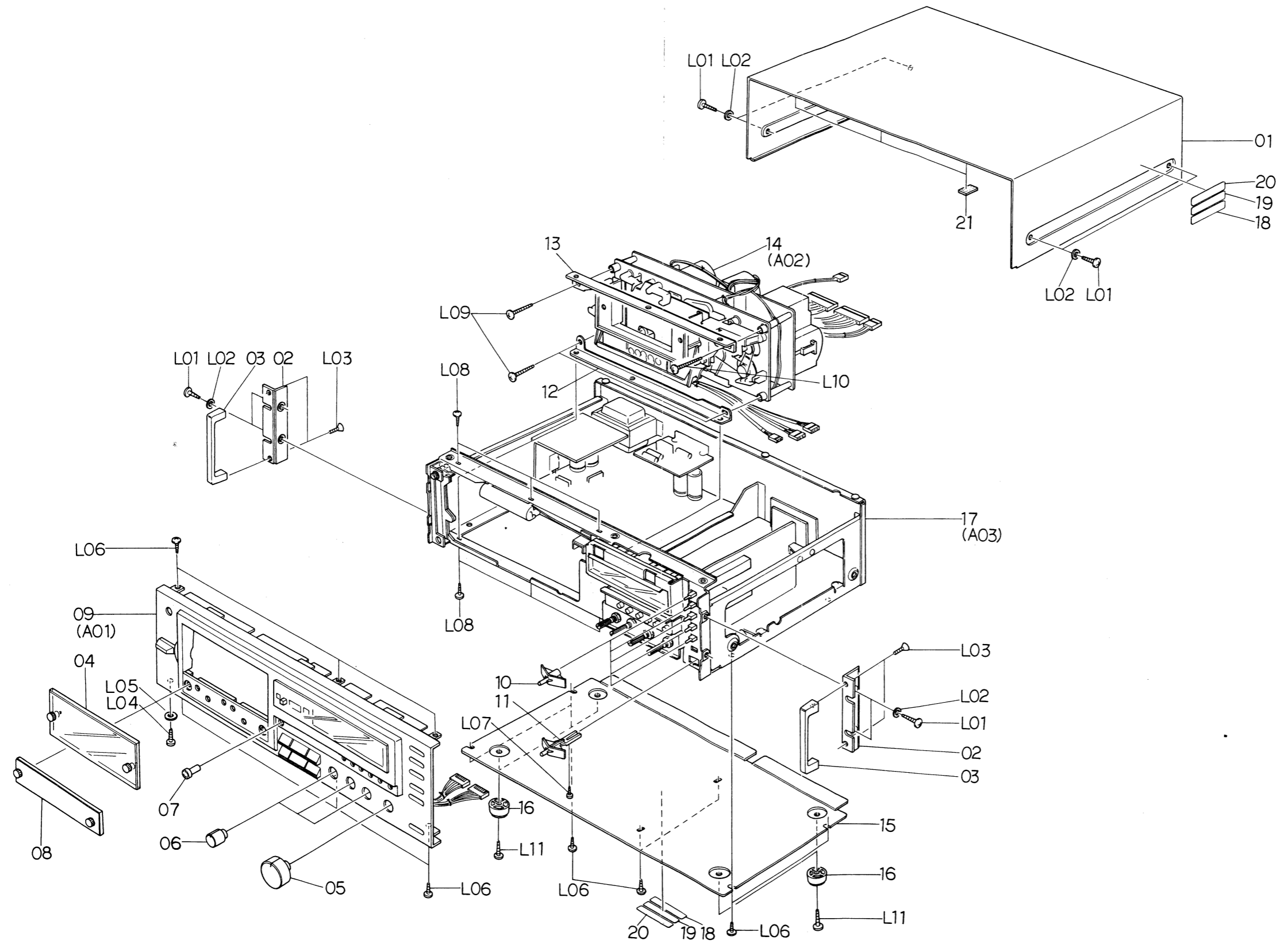

Fig. 8.1

Schematic Ref. No.	Part No.	Description	Q'ty	Schematic Ref. No.	Part No.	Description	Q'ty
		<b>Synthesis</b> Serial No.: A30704151 -				<b>Synthesis</b> Serial Nos.: A30704141 - A30704150	
01	0H03723D	Top Cover	1	01	0H03723D	Top Cover	1
02	0H03788B	Side Panel B	2	02	0H03788B	Side Panel B	2
03	0H03763B	Handle B	2	03	0H03763B	Handle B	2
04	HA03882A	Cassette Case Cover Ass'y	1	04	HA03882A	Cassette Case Cover Ass'y	1
05	0H03732B	Volume Knob A	1	05	0H03732B	Volume Knob A	1
(05)	0H03733A	Volume Knob Sleeve A	1	(05)	0H03733A	Volume Knob Sleeve A	1
06	0H03738B	Volume Knob B	3	06	0H03738B	Volume Knob B	3
(06)	0H03739A	Volume Knob Sleeve B	3	(06)	0H03739A	Volume Knob Sleeve B	3
07	0H03725A	Pitch Control Knob	1	07	0H03725A	Pitch Control Knob	1
08	HA03981A	Azimuth Alignment Cover Ass'y	1	08	HA03981A	Azimuth Alignment Cover Ass'y	1
09	HA03980A	Front Panel Ass'y	1	09	HA03980A	Front Panel Ass'y	1
10	HA03838B	Function Switch Knob Ass'y	6	10	HA03838B	Function Switch Knob Ass'y	6
11	0H03741A	Power Switch Knob	1	11	0H03741A	Power Switch Knob	1
12	0J04054B	Mechanism Holder B	1	12	0J04054B	Mechanism Holder B	1
13	0J04053A	Mechanism Holder A	1	13	0J04053A	Mechanism Holder A	1
14	CA08230A	Mechanism Ass'y 660ZX	1	14	CA08145C	Mechanism Ass'y 660ZX	1
15	0H03757A	Bottom Cover	1	15	0H03757A	Bottom Cover	1
16	0J03825A	Leg S	4	16	0J03825A	Leg S	4
17	JA03652A	Chassis Ass'y (U.S.A. & Canada)	1	17	JA03652A	Chassis Ass'y (U.S.A. & Canada)	1
	JA03653A	Chassis Ass'y (Japan)	1		JA03653A	Chassis Ass'y (Japan)	1
	JA03654A	Chassis Ass'y (220V Class 2)	1		JA03654A	Chassis Ass'y (220V Class 2)	1
	JA03655A	Chassis Ass'y (Australia)	1		JA03655A	Chassis Ass'y (Australia)	1
	JA03656A	Chassis Ass'y (UK)	1		JA03656A	Chassis Ass'y (UK)	1
	JA03657A	Chassis Ass'y (Others)	1		JA03657A	Chassis Ass'y (Others)	1
18	0M03799A	Caution Label G	2	18	0M03799A	Caution Label G	2
*19	0M03800A	Caution Label H (U.S.A. & Canada)	2	*19	0M03800A	Caution Label H (U.S.A. & Canada)	2
*20	0M03883A	Lamp Caution Label (U.S.A. & Canada)	2	*20	0M03883A	Lamp Caution Label (U.S.A. & Canada)	2
21	0J04080A	Top Cover Himelon	4	21	0J04080A	Top Cover Himelon	4
L01	0E00915A	BT Screw M4x8 Philips Binding Head (Black Chromate)	8	L01	0E00915A	BT Screw M4x8 Philips Binding Head (Black Chromate)	8
L02	0E00736A	Washer 4mm (Black Chromate)	8	L02	0E00736A	Washer 4mm (Black Chromate)	8
L03	0E00908A	Screw M4x6 Philips Countersunk	4	L03	0E00908A	Screw M4x6 Philips Countersunk	4
L04	0E00921A	BT Screw M3x8 Philips Binding Head (Black Chromate)	1	L04	0E00921A	BT Screw M3x8 Philips Binding Head (Black Chromate)	1
L05	0E00677A	Washer 3mm (Black Chromate)	1	L05	0E00677A	Washer 3mm (Black Chromate)	1
L06	0E00857A	BT Screw M3x6 Philips Binding Head	12	L06	0E00857A	BT Screw M3x6 Philips Binding Head	12
L07	0E00814A	ST Screw M2x4 Philips Pan Head	1	L07	0E00814A	ST Screw M2x4 Philips Pan Head	1
L08	0E00920A	Screw M3x6 Philips Polywave	6	L08	0E00920A	Screw M3x6 Philips Polywave	6
L09	0E00867A	BT Screw M4x15 Philips Binding Head	3	L09	0E00867A	BT Screw M4x15 Philips Binding Head	3
L10	0E00878A	BT Screw M4x20 Philips Binding Head	1	L10	0E00878A	BT Screw M4x20 Philips Binding Head	1
L11	0E00852A	BT Screw M4x12 Philips Binding Head	4	L11	0E00852A	BT Screw M4x12 Philips Binding Head	4
		*: Depends on the versions.				*: Depends on the versions.	

Schematic Ref. No.	Part No.	Description	Q'ty	Schematic Ref. No.	Part No.	Description	Q'ty
		<b>Synthesis</b> Serial Nos.: A30703405 – A30704140				<b>Synthesis</b> Serial Nos.: A30701001 – A30703404	
01	0H03723D	Top Cover	1	01	0H03723D	Top Cover	1
02	0H03788B	Side Panel B	2	02	0H03788B	Side Panel B	2
03	0H03763B	Handle B	2	03	0H03763B	Handle B	2
04	HA03882A	Cassette Case Cover Ass'y	1	04	HA03882A	Cassette Case Cover Ass'y	1
05	0H03732B	Volume Knob A	1	05	0H03732B	Volume Knob A	1
(05)	0H03733A	Volume Knob Sleeve A	1	(05)	0H03733A	Volume Knob Sleeve A	1
06	0H03738B	Volume Knob B	3	06	0H03738B	Volume Knob B	3
(06)	0H03739A	Volume Knob Sleeve B	3	(06)	0H03739A	Volume Knob Sleeve B	3
07	0H03725A	Pitch Control Knob	1	07	0H03725A	Pitch Control Knob	1
08	HA03981A	Azimuth Alignment Cover Ass'y	1	08	HA03981A	Azimuth Alignment Cover Ass'y	1
09	HA03980A	Front Panel Ass'y	1	09	HA03980A	Front Panel Ass'y	1
10	HA03838B	Function Switch Knob Ass'y	6	10	HA03838B	Function Switch Knob Ass'y	6
11	0H03741A	Power Switch Knob	1	11	0H03741A	Power Switch Knob	1
12	0J04054B	Mechanism Holder B	1	12	0J04054B	Mechanism Holder B	1
13	0J04053A	Mechanism Holder A	1	13	0J04053A	Mechanism Holder A	1
14	CA08145B	Mechanism Ass'y 660ZX	1	14	CA08145A	Mechanism Ass'y 660ZX	1
15	0H03757A	Bottom Cover	1	15	0H03757A	Bottom Cover	1
16	0J03825A	Leg S	4	16	0J03825A	Leg S	4
17	JA03652A	Chassis Ass'y (U.S.A. & Canada)	1	17	JA03652A	Chassis Ass'y (U.S.A. & Canada)	1
	JA03653A	Chassis Ass'y (Japan)	1		JA03653A	Chassis Ass'y (Japan)	1
	JA03654A	Chassis Ass'y (220V Class 2)	1		JA03654A	Chassis Ass'y (220V Class 2)	1
	JA03655A	Chassis Ass'y (Australia)	1		JA03655A	Chassis Ass'y (Australia)	1
	JA03656A	Chassis Ass'y (UK)	1		JA03656A	Chassis Ass'y (UK)	1
	JA03657A	Chassis Ass'y (Others)	1		JA03657A	Chassis Ass'y (Others)	1
18	0M03799A	Caution Label G	2	18	0M03799A	Caution Label G	2
* 19	0M03800A	Caution Label H (U.S.A. & Canada)	2	* 19	0M03800A	Caution Label H (U.S.A. & Canada)	2
* 20	0M03883A	Lamp Caution Label (U.S.A. & Canada)	2	* 20	0M03883A	Lamp Caution Label (U.S.A. & Canada)	2
21	0J04080A	Top Cover Himelon	4	21	0J04080A	Top Cover Himelon	4
L01	0E00915A	BT Screw M4x8 Philips Binding Head (Black Chromate)	8	L01	0E00915A	BT Screw M4x8 Philips Binding Head (Black Chromate)	8
L02	0E00736A	Washer 4mm (Black Chromate)	8	L02	0E00736A	Washer 4mm (Black Chromate)	8
L03	0E00908A	Screw M4x6 Philips Countersunk	4	L03	0E00908A	Screw M4x6 Philips Countersunk	4
L04	0E00921A	BT Screw M3x8 Philips Binding Head (Black Chromate)	1	L04	0E00921A	BT Screw M3x8 Philips Binding Head (Black Chromate)	1
L05	0E00677A	Washer 3mm (Black Chromate)	1	L05	0E00677A	Washer 3mm (Black Chromate)	1
L06	0E00857A	BT Screw M3x6 Philips Binding Head	12	L06	0E00857A	BT Screw M3x6 Philips Binding Head	12
L07	0E00814A	ST Screw M2x4 Philips Pan Head	1	L07	0E00814A	ST Screw M2x4 Philips Pan Head	1
L08	0E00920A	Screw M3x6 Philips Polywave	6	L08	0E00920A	Screw M3x6 Philips Polywave	6
L09	0E00867A	BT Screw M4x15 Philips Binding Head	3	L09	0E00867A	BT Screw M4x15 Philips Binding Head	3
L10	0E00878A	BT Screw M4x20 Philips Binding Head	1	L10	0E00878A	BT Screw M4x20 Philips Binding Head	1
L11	0E00852A	BT Screw M4x12 Philips Binding Head	4	L11	0E00852A	BT Screw M4x12 Philips Binding Head	4
		*: Depends on the versions.				*: Depends on the versions.	



**8.2. Front Panel Ass'y (A01)**

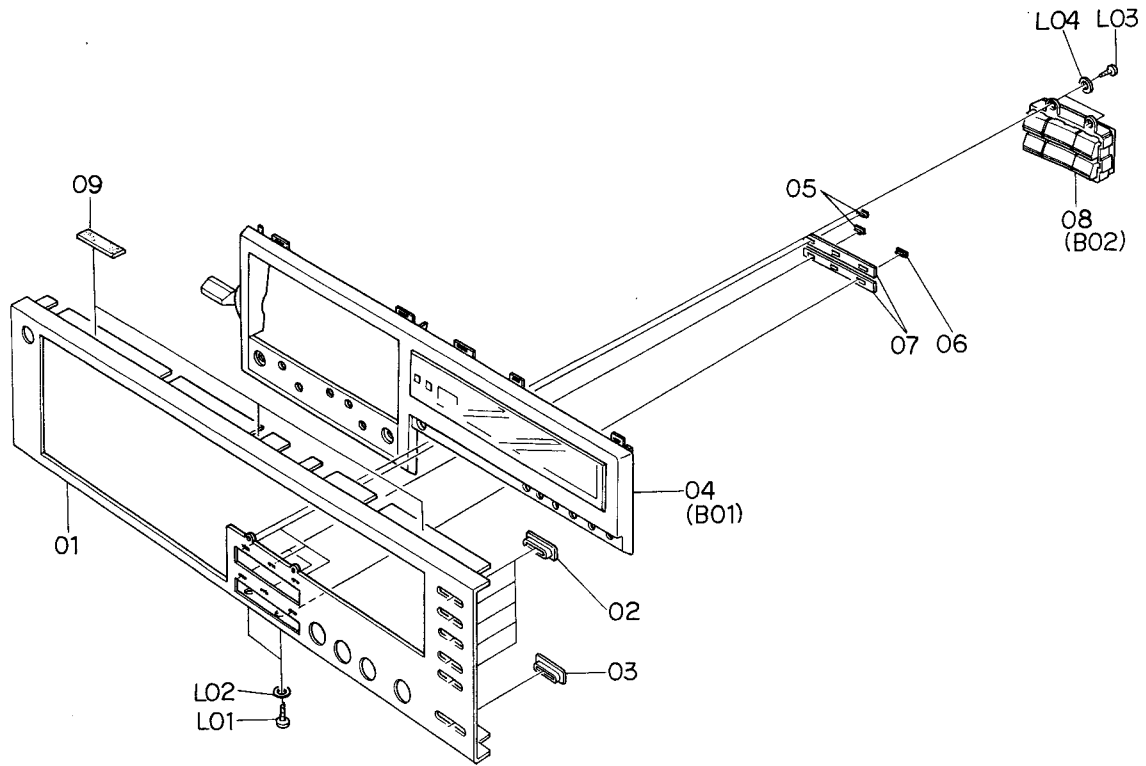

**Fig. 8.2**

Schematic Ref. No.	Part No.	Description	Q'ty
<b>A01</b>	<b>HA03980A</b>	<b>Front Panel Ass'y</b> Serial No.: A30701001 –	<b>1</b>
01	0H03822A	Front Panel	1
02	0H03746A	Function Switch Escutcheon	1
03	0H03747C	Power Switch Escutcheon	1
04	HA03951B	Front Panel Escutcheon Ass'y	1
05	0H03744B	Green Lens	5
06	0H03745B	Orange Lens	1
07	0J04059B	Light Intercepting Seal A	2
08	HA03823A	Control Button Ass'y	1
09	0H03781A	Cushion	1
L01	0E00825A	BT Screw M2.6x8 Philips Binding Head	2
L02	0E00912A	Washer FT25	2
L03	0E00794A	BT Screw M2x5 Philips Pan Head	2
L04	0E00117A	Washer 2mm	2

## 8.3. Mechanism Ass'y 660ZX (A02)

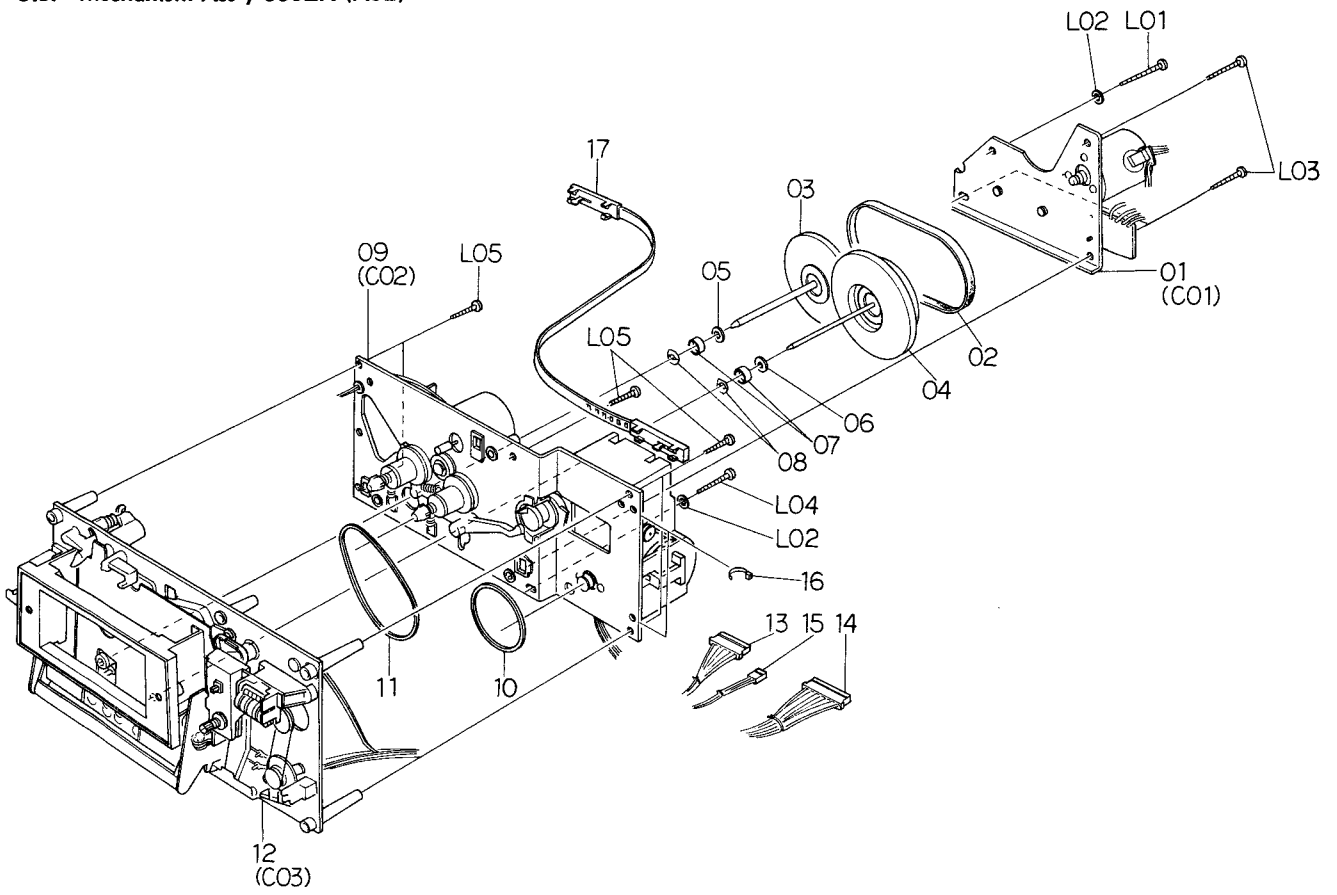

Fig. 8.3

Schematic Ref. No.	Part No.	Description	Q'ty	Schematic Ref. No.	Part No.	Description	Q'ty
<b>A02</b>	<b>CA08230A</b>	<b>Mechanism Ass'y 660ZX</b> Serial No.: A30704151 –	<b>1</b>	<b>A02</b>	<b>CA08145B</b>	<b>Mechanism Ass'y 660ZX</b> Serial Nos.: A30703405 – A30704140	<b>1</b>
01	CA08156A	Flywheel Holder Ass'y	1	01	CA08156A	Flywheel Holder Ass'y	1
02	0C08096C	Capstan Belt	1	02	0C08096C	Capstan Belt	1
03	CA08173A	Supply Flywheel Ass'y D	1	03	CA08173A	Supply Flywheel Ass'y D	1
04	CA08015A	Take-up Flywheel Ass'y	1	04	CA08015A	Take-up Flywheel Ass'y	1
05	0C08021B	Thrust Washer 3.1mm	1	05	0C08021B	Thrust Washer 3.1mm	1
06	0C08020B	Thrust Washer 2.6mm	1	06	0C08020B	Thrust Washer 2.6mm	1
07	0C08069C	Flange Thrust Cap	2	07	0C08069C	Flange Thrust Cap	2
08	0C08022B	Flange Thrust Spring	2	08	0C08022B	Flange Thrust Spring	2
09	CA08235A	Sub Mechanism Chassis Ass'y	1	09	CA08146A	Sub Mechanism Chassis Ass'y	1
10	0C08099B	Control Motor Belt	1	10	0C08099B	Control Motor Belt	1
11	0C08098B	Counter Belt B	1	11	0C08098B	Counter Belt B	1
12	CA08220A	Main Mechanism Chassis Ass'y	1	12	CA08179A	Main Mechanism Chassis Ass'y	1
13	0B08650B	9P-H Connector	1	13	0B08650B	9P-H Connector	1
14	0B08651D	11P-H Connector	1	14	0B08651D	11P-H Connector	1
15	0B08652C	3P-H Connector	1	15	0B08652C	3P-H Connector	1
16	0B08515A	Insh-Lock	15	16	0B08515A	Insh-Lock	15
17	0C08237A	Azimuth Alignment Wire	1	17	0C08237A	Azimuth Alignment Wire	1
–	0M04154A	Mechanism Serial No. Seal	1	–	0M04154A	Mechanism Serial No. Seal	1
L01	0E00834A	BT Screw M3x30 Philips Pan Head	1	L01	0E00834A	BT Screw M3x30 Philips Pan Head	1
L02	0E00178A	Washer 3mm	2	L02	0E00178A	Washer 3mm	2
L03	0E00833A	BT Screw M3x20 Philips Pan Head	3	L03	0E00833A	BT Screw M3x20 Philips Pan Head	3
L04	0E00835A	BT Screw M3x25 Philips Pan Head	1	L04	0E00835A	BT Screw M3x25 Philips Pan Head	1
L05	0E00883A	BT Screw M3x18 Philips Pan Head	5	L05	0E00883A	BT Screw M3x18 Philips Pan Head	5
<b>A02</b>	<b>CA08145C</b>	<b>Mechanism Ass'y 660ZX</b> Serial Nos.: A30704141 – A30704150	<b>1</b>	<b>A02</b>	<b>CA08145A</b>	<b>Mechanism Ass'y 660ZX</b> Serial Nos.: A30701001 – A30703404	<b>1</b>
01	CA08156A	Flywheel Holder Ass'y	1	01	CA08156A	Flywheel Holder Ass'y	1
02	0C08096C	Capstan Belt	1	02	0C08096C	Capstan Belt	1
03	CA08173A	Supply Flywheel Ass'y D	1	03	CA08014A	Supply Flywheel Ass'y	1
04	CA08015A	Take-up Flywheel Ass'y	1	04	CA08015A	Take-up Flywheel Ass'y	1
05	0C08021B	Thrust Washer 3.1mm	1	05	0C08021B	Thrust Washer 3.1mm	1
06	0C08020B	Thrust Washer 2.6mm	1	06	0C08020B	Thrust Washer 2.6mm	1
07	0C08069C	Flange Thrust Cap	2	07	0C08069C	Flange Thrust Cap	2
08	0C08022B	Flange Thrust Spring	2	08	0C08022B	Flange Thrust Spring	2
09	CA08202A	Sub Mechanism Chassis Ass'y	1	09	CA08146A	Sub Mechanism Chassis Ass'y	1
10	0C08099B	Control Motor Belt	1	10	0C08099B	Control Motor Belt	1
11	0C08098B	Counter Belt B	1	11	0C08098B	Counter Belt B	1
12	CA08210A	Main Mechanism Chassis Ass'y	1	12	CA08153A	Main Mechanism Chassis Ass'y	1
13	0B08650B	9P-H Connector	1	13	0B08650B	9P-H Connector	1
14	0B08651D	11P-H Connector	1	14	0B08651D	11P-H Connector	1
15	0B08652C	3P-H Connector	1	15	0B08652C	3P-H Connector	1
16	0B08515A	Insh-Lock	15	16	0B08515A	Insh-Lock	15
17	0C08237A	Azimuth Alignment Wire	1	17	0C08237A	Azimuth Alignment Wire	1
–	0M04154A	Mechanism Serial No. Seal	1	–	0M04154A	Mechanism Serial No. Seal	1
L01	0E00834A	BT Screw M3x30 Philips Pan Head	1	L01	0E00834A	BT Screw M3x30 Philips Pan Head	1
L02	0E00178A	Washer 3mm	2	L02	0E00178A	Washer 3mm	2
L03	0E00833A	BT Screw M3x20 Philips Pan Head	3	L03	0E00833A	BT Screw M3x20 Philips Pan Head	3
L04	0E00835A	BT Screw M3x25 Philips Pan Head	1	L04	0E00835A	BT Screw M3x25 Philips Pan Head	1
L05	0E00883A	BT Screw M3x18 Philips Pan Head	5	L05	0E00883A	BT Screw M3x18 Philips Pan Head	5

Schematic Ref. No.	Part No.	Description	Q'ty	Schematic Ref. No.	Part No.	Description	Q'ty					
A03	JA03652A	Chassis Ass'y (U.S.A. & Canada)	1	B01	HA03951B	Front Panel Escutcheon Ass'y Serial No.: A30701001 -	1					
	JA03653A	Chassis Ass'y (Japan)	1									
	JA03654A	Chassis Ass'y (220V Class 2)	1									
	JA03655A	Chassis Ass'y (Australia)	1									
	JA03656A	Chassis Ass'y (UK)	1									
	JA03657A	Chassis Ass'y (Others)	1									
	Serial No.:		A30701001 -									
	01	0B08716A	Level Meter					1	01	HA03982C	Front Panel Escutcheon Sub Ass'y	1
	02	0H03829B	Meter Holder					1	02	0H03722B	Display Glass	1
	03	JA03661A	Record Calibration Ass'y					1	03	0H03826B	Display Glass Hold Plate	1
	04	JA03658A	Volume Holder Ass'y					1	04	BA04209A	RAMM P.C.B. Ass'y	1
	05	JA03659A	Headphone Jack Ass'y					1	05	0H03830A	LED Filter	1
	06	JA03600A	Reflector Ass'y					1	06	0J04050A	Counter Escutcheon Holder	1
	07	JA03602A	Counter Lamp Ass'y					1	07	0H03749A	Memory Switch Knob	1
08	0J04034F	Front Chassis	1	08	0J04043A	Memory Switch Knob Spring	1					
09	BA04190A	Switch P.C.B. Ass'y	1	09	0H03743B	Counter Reset Knob Holder	1					
10	BA04191A	Main P.C.B. Ass'y	1	10	0H03750A	Counter Reset Knob	1					
11	BA04192A	Logic P.C.B. Ass'y	1	11	0J04042A	Counter Reset Knob Spring	1					
12	BA04207A	Auto Azimuth P.C.B. Ass'y	1	12	0H03724F	Eject Lever	1					
13	0J04033C	Side Chassis Right	1	13	0H03762A	Eject Lever Spring	1					
14	JA03592A	Power Switch Holder Ass'y (U.S.A., Canada & Others)	1	14	0J04057B	Eject Lever Cushion	1					
	JA03595A	Power Switch Holder Ass'y (Japan)	1	L01	0E00874A	Stopper Ring CS 2mm	5					
	JA03594A	Power Switch Holder Ass'y (220V Class 2, Australia & UK)	1	L02	0E00854A	BT Screw M2.6x6 Philips Pan Head	4					
15	0J04055B	Switch P.C.B. Holder	1	L03	0E00890A	C-Ring 2mm	1					
16	0J04032D	Center Chassis	1	L04	0E00837A	Stopper Ring 3mm	1					
17	0J04031B	Side Chassis Left	1	B02	HA03823A	Control Button Ass'y Serial No.: A30701001 -	1					
18	HA03945A	Rear Panel Ass'y (U.S.A. & Canada)	1					01	0H03726B	Control Button Stop	1	
	HA03946A	Rear Panel Ass'y (Japan)	1					02	0H03727B	Control Button Play	1	
	HA03950A	Rear Panel Ass'y (220V Class 2)	1					03	0H03728B	Control Button F.F.	1	
	HA03949A	Rear Panel Ass'y (Australia)	1					04	0H03729B	Control Button Rewind	1	
	HA03948A	Rear Panel Ass'y (UK)	1					05	0H03730B	Control Button Pause	1	
	HA03947A	Rear Panel Ass'y (Others)	1					06	0H03731B	Control Button Record	1	
19	0J04062B	Insulator	2					07	0J04044C	Control Button Holder	1	
20	0B08515A	Insu-Lock	23					08	0J04045B	Control Button Shaft	2	
21	0J04064A	Free Bushing 85mm	1					09	0J04046A	Control Button Spring	6	
* 22	0M03700A	Earth Mark Label	1					10	0J04052B	Spring Stopper	6	
23	0B08580A	Wire Holder 161	1					11	0J04099A	Control Button Himelon	2	
L01	0E00857A	BT Screw M3x6 Philips Binding Head	36					12	BA04071A	Control Switch P.C.B. Ass'y	1	
L02	0E00868A	BT Screw M3x8 Philips Binding Head	6					L01	0E00792A	BT Screw M2.6x6 Philips Pan Head	6	
L03	0E00859A	BT Screw M2.6x6 Philips Binding Head	3	L02	0J04061A	Washer FT20	8					
L04	0E00622A	Screw M3x5 Philips Pan Head (2A)	6	C01	CA08156A	Flywheel Holder Ass'y Serial No.: A30701001 -	1					
L05	0E00860A	BT Screw M3x6 Philips Binding Head (Black Chromate)	6					01	0C08013I	Flywheel Holder	1	
* L06	0E00521A	Screw M3x8 Philips Pan Head	1					02	0C08238A	Capstan Motor	1	
* L07	0E00507A	Nut Hex. M3	1					03	0C08079G	Capstan Motor Pulley	1	
* L08	0E00581A	Washer 3mm (Spring)	1					04	-	Speed Cal. P.C.B. Ass'y (incorporated in the Capstan Motor)	(1)	
* L09	0E00037A	Earth Lug B-5	1					L01	0E00226A	Screw M2.6x4 Philips Pan Head	3	
								L02	0C08068C	Thrust Screw	2	
								L03	0C03857A	Lock Nut	2	
				L04	0E00862A	BT Screw M3x6 Philips Pan Head	1					
		*: Depends on the versions.										

8.4. Chassis Ass'y (A03)

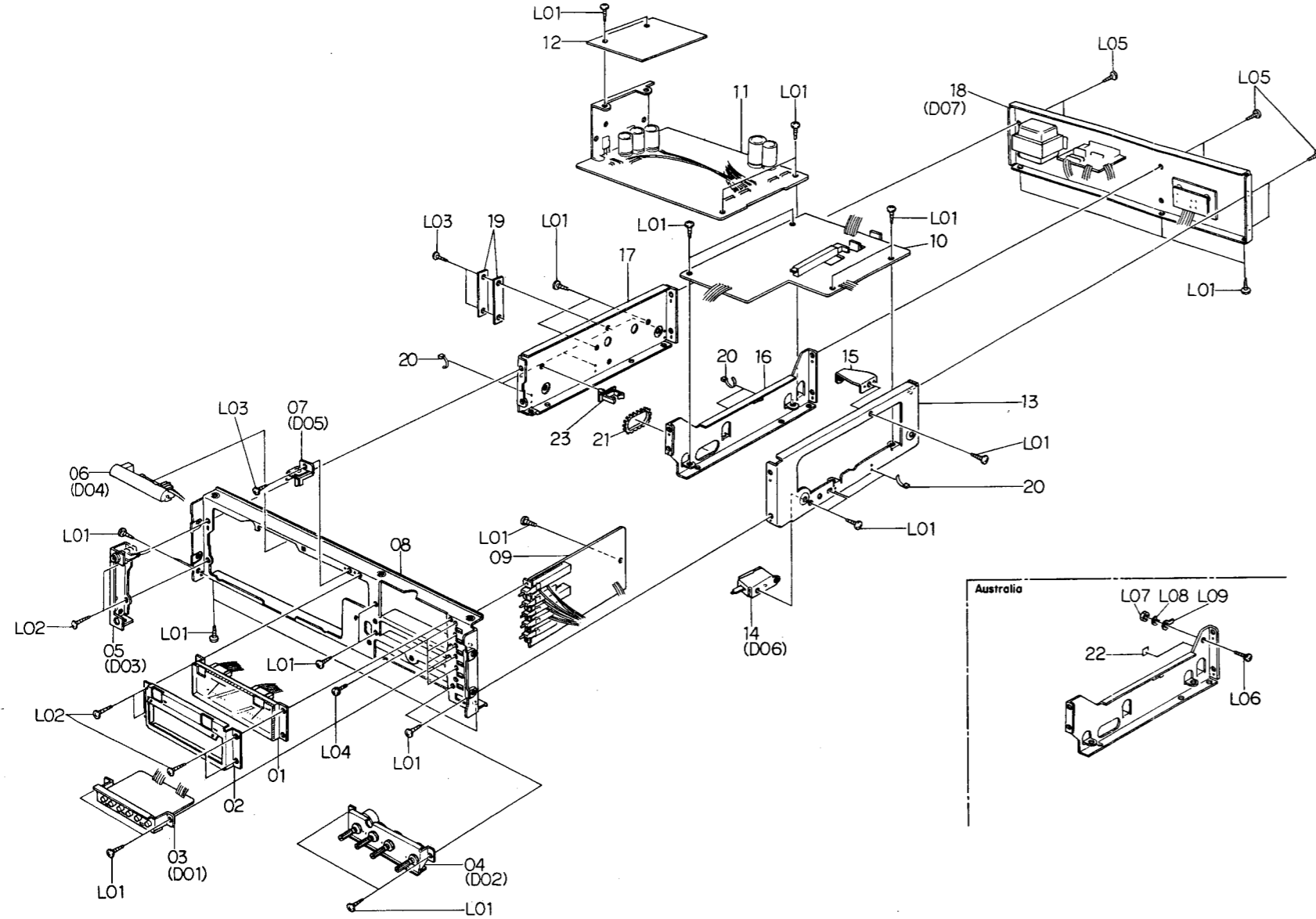

Fig. 8.4

8.5. Front Panel Escutcheon Ass'y (B01)

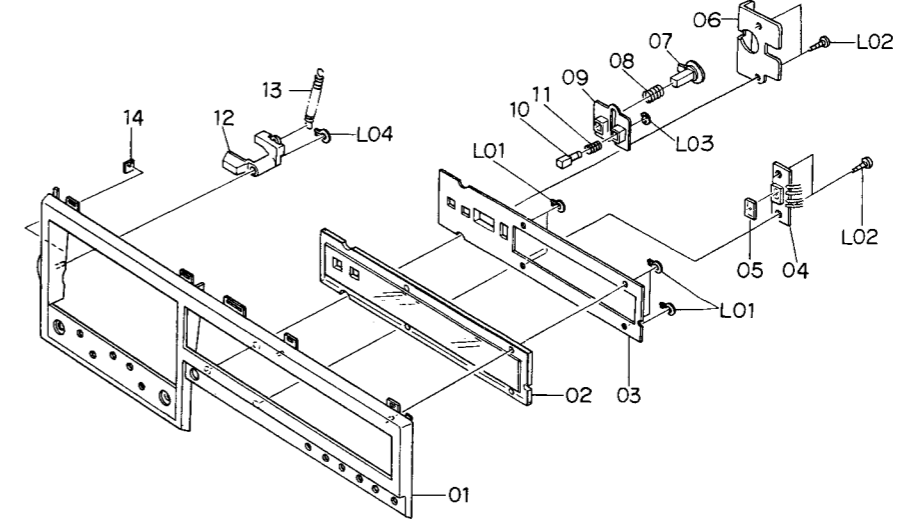

Fig. 8.5

8.6. Control Button Ass'y (B02)

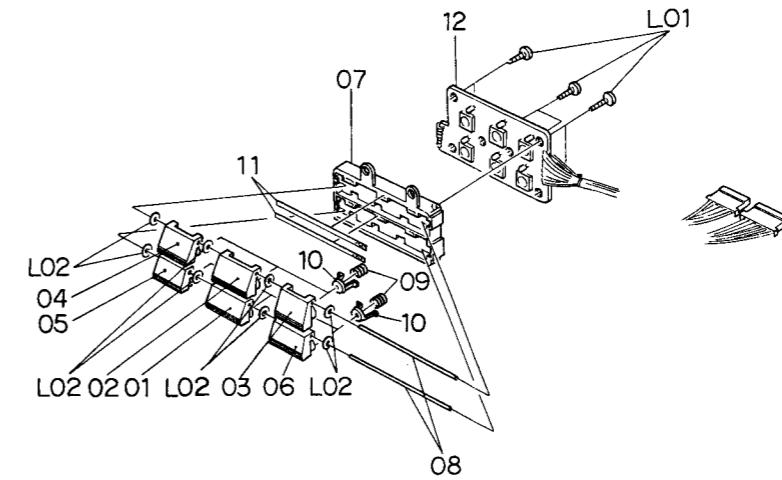

Fig. 8.6

8.7. Flywheel Holder Ass'y (C01)

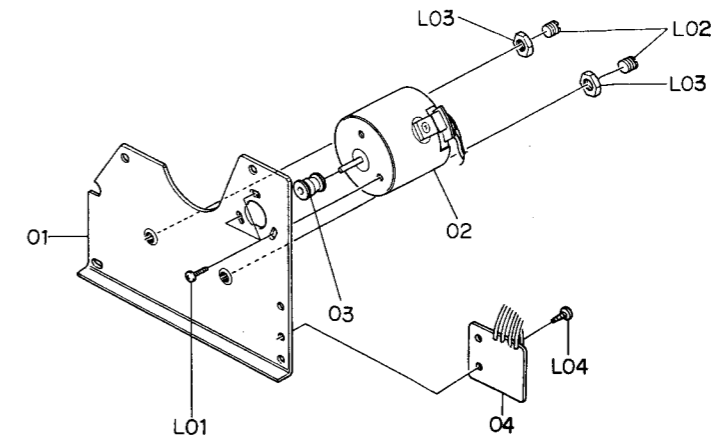

Fig. 8.7

8.8. Sub Mechanism Chassis Ass'y (C02)

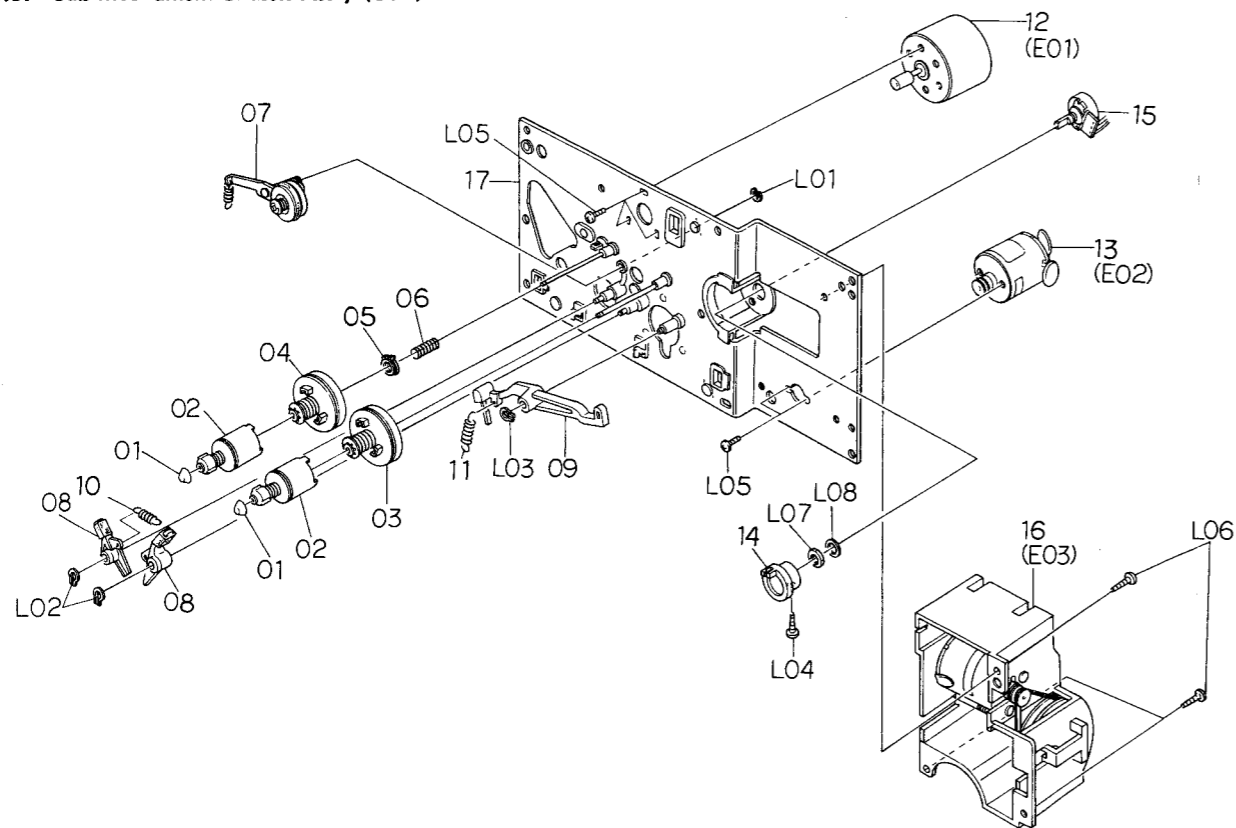

Fig. 8.8.1 Serial No.: A30704151 -

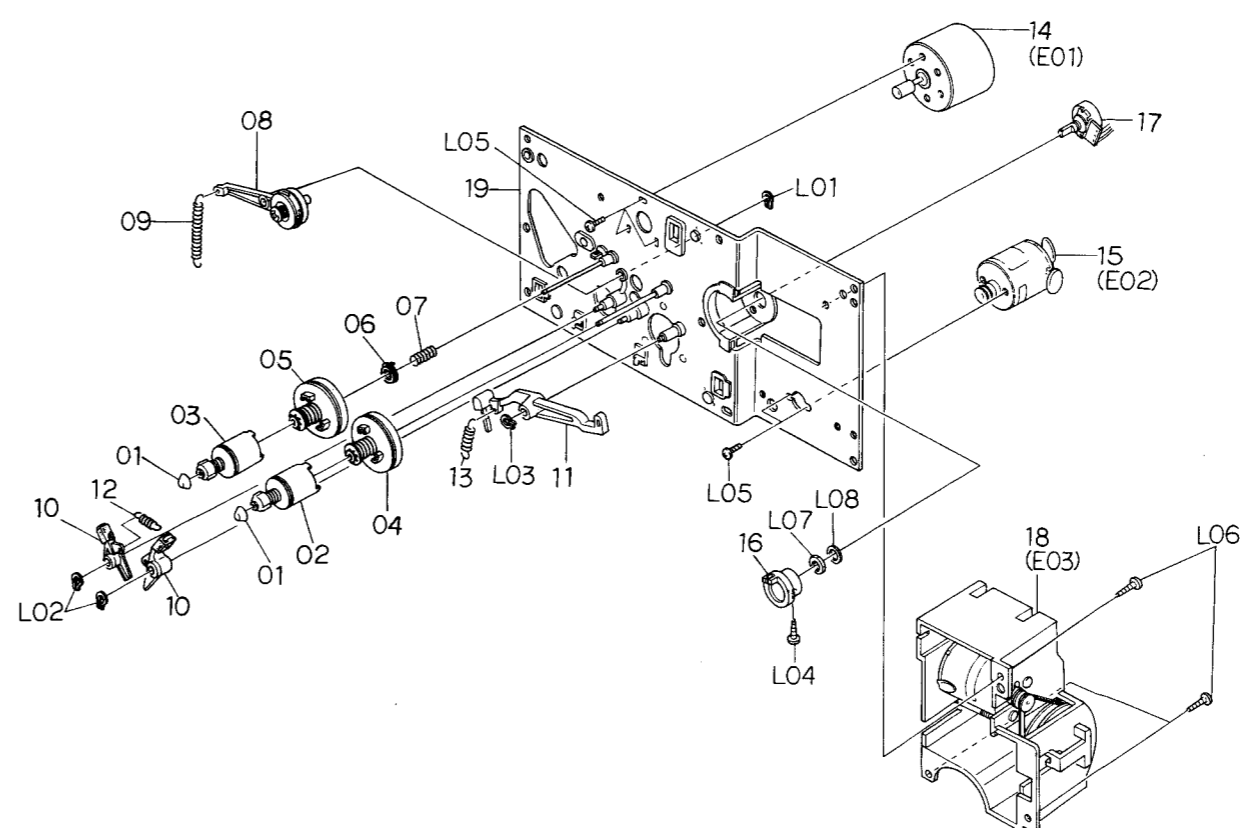

Fig. 8.8.2 Serial Nos.: A30704141 - A30704150

Schematic Ref. No.	Part No.	Description	Q'ty	Schematic Ref. No.	Part No.	Description	Q'ty	Schematic Ref. No.	Part No.	Description	Q'ty	Schematic Ref. No.	Part No.	Description	Q'ty
C02	CA08235A	Sub Mechanism Chassis Ass'y Serial No.: A30704151 -	1	L05	0E00226A	Screw M2.6x4 Philips Pan Head	5	C02	CA08202A	Sub Mechanism Chassis Ass'y Serial Nos.: A30704141 - A30704150	1	L04	0E00859A	BT Screw M2.6x6 Philips Binding Head	1
				L06	0E00846A	BT Screw M3x8 Philips Pan Head	3					L05	0E00226A	Screw M2.6x4 Philips Pan Head	5
01	0C08039B	Reel Hub Head	2	L07	-	Volume Nut	(1)	01	0C08039B	Reel Hub Head	2	L06	0E00846A	BT Screw M3x8 Philips Pan Head	3
02	CA08038C	Reel Hub B Ass'y	2	L08	-	Volume Washer	(1)	02	CA08038B	Reel Hub B Ass'y	1	L07	-	Volume Nut	(1)
03	CA08037A	Reel Hub Take-up Ass'y	1					03	CA08197A	Reel Hub B Ass'y	1	L08	-	Volume Washer	(1)
04	CA08064A	Reel Hub Supply Ass'y	1					04	CA08037A	Reel Hub Take-up Ass'y	1				
05	CA08039A	Back Tension Ass'y	1					05	CA08064A	Reel Hub Supply Ass'y	1				
06	0C08178A	Back Tension Spring	1					06	CA08039A	Back Tension Ass'y	1				
07	CA08193A	Idler Ass'y	1					07	0C08178A	Back Tension Spring	1				
08	CA08042A	Brake Ass'y	2					08	CA08040A	Idler Ass'y	1				
09	0C08030C	Brake Drive Arm	1					09	0C08127B	Idler Arm Spring	1				
10	0C08129A	Brake Arm Spring	1					10	CA08042A	Brake Ass'y	2				
11	0C08128A	Brake Drive Arm Spring	1					11	0C08030C	Brake Drive Arm	1				
12	CA08117B	Reel Motor Ass'y	1					12	0C08129A	Brake Arm Spring	1				
13	CA08034A	Control Motor Ass'y	1					13	0C08128A	Brake Drive Arm Spring	1				
14	0C08053B	Volume Coupler	1					14	CA08117B	Reel Motor Ass'y	1				
15	0B07240A	Volume Control 10kΩ (B)	1					15	CA08034A	Control Motor Ass'y	1				
16	CA08148A	Azimuth Alignment Motor Ass'y	1					16	0C08053B	Volume Coupler	1				
17	CA08041A	Sub Chassis Ass'y	1					17	0B07240A	Volume Control 10kΩ (B)	1				
L01	0E00698A	E-Ring 2.5mm	1					18	CA08148A	Azimuth Alignment Motor Ass'y	1				
L02	0E00837A	Stopper Ring 3mm	2					19	CA08041A	Sub Chassis Ass'y	1				
L03	0E00838A	Stopper Ring 4mm	1					L01	0E00842A	Stopper Ring 2mm	1				
L04	0E00859A	BT Screw M2.6x6 Philips Binding Head	1					L02	0E00837A	Stopper Ring 3mm	2				
								L03	0E00838A	Stopper Ring 4mm	1				

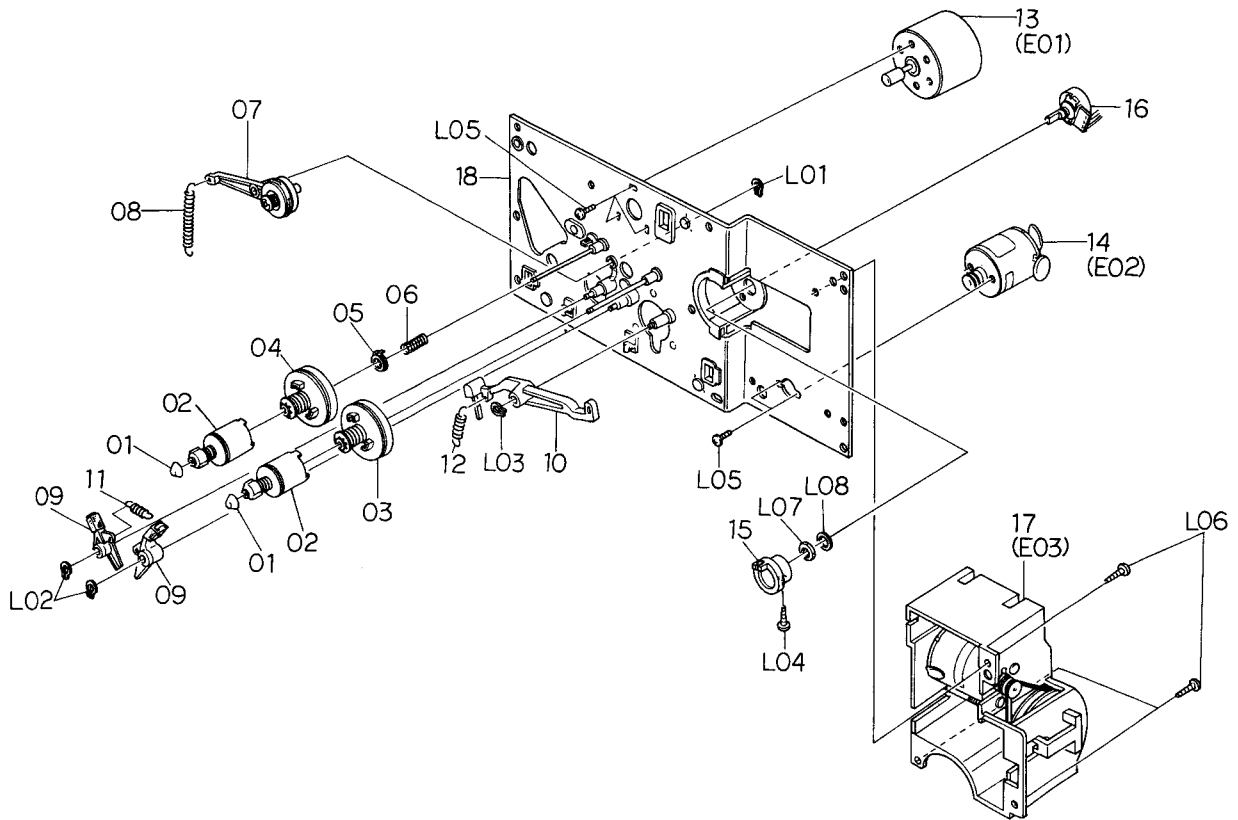

Fig. 8.8.3 Serial Nos.: A30701001 – A30704140

Schematic Ref. No.	Part No.	Description	Q'ty	Schematic Ref. No.	Part No.	Description	Q'ty
C02	CA08146A	Sub Mechanism Chassis Ass'y Serial Nos.: A30701001 – A30704140	1	L04	0E00859A	BT Screw M2.6x6 Philips Binding Head	1
				L05	0E00226A	Screw M2.6x4 Philips Pan Head	5
				L06	0E00846A	BT Screw M3x8 Philips Pan Head	3
01	0C08039B	Reel Hub Head	2	L07	—	Volume Nut	(1)
02	CA08038B	Reel Hub B Ass'y	2	L08	—	Volume Washer	(1)
03	CA08037A	Reel Hub Take-up Ass'y	1				
04	CA08064A	Reel Hub Supply Ass'y	1				
05	CA08039A	Back Tension Ass'y	1				
06	0C08178A	Back Tension Spring	1				
07	CA08040A	Idler Ass'y	1				
08	0C08127B	Idler Arm Spring	1				
09	CA08042A	Brake Ass'y	2				
10	0C08030C	Brake Drive Arm	1				
11	0C08129A	Brake Arm Spring	1				
12	0C08128A	Brake Drive Arm Spring	1				
13	CA08117B	Reel Motor Ass'y	1				
14	CA08034A	Control Motor Ass'y	1				
15	0C08053B	Volume Coupler	1				
16	0B07240A	Volume Control 10kΩ (B)	1				
17	CA08148A	Azimuth Alignment Motor Ass'y	1				
18	CA08041A	Sub Chassis Ass'y	1				
L01	0E00842A	Stopper Ring 2mm	1				
L02	0E00837A	Stopper Ring 3mm	2				
L03	0E00838A	Stopper Ring 4mm	1				

Schematic Ref. No.	Part No.	Description	Q'ty	Schematic Ref. No.	Part No.	Description	Q'ty
C03	CA08210A	Main Mechanism Chassis Ass'y Serial No.: A30704141 -	1	L11	0E00879A	BT Screw M2x15 Philips Pan Head	1
				L12	0E00838A	Stopper Ring 4mm	3
				L13	0E00846A	BT Screw M3x8 Philips Pan Head	3
				L14	0E00865A	BT Screw M3x10 Philips Binding Head	2
01	CA08125A	Cassette Case Holder L Ass'y	1				
02	0C08151A	Lid Arm Spring Tube	1				
03	CA08022A	Cassette Case Holder R Ass'y	1	L15	0E00895A	Earth Lug 3mm	2
04	CA08163A	Cassette Case Ass'y	1	L16	0E00859A	BT Screw M2.6x6 Philips Binding Head	1
05	0C08019I	Cover Plate	1				
06	0M03977A	Cassette Viewer Label	1	L17	0C08255A	Washer 2.6mm	1
07	CA08147A	Head Mount Base Ass'y	1				
08	0C08121A	Supply Pressure Roller Spring	1				
09	CA08053B	Supply Pressure Roller Ass'y	1				
10	0C08122B	Supply Pressure Roller Thrust Spring	1				
11	CA08079B	Take-up Pressure Roller Ass'y	1				
12	0C08183B	Take-up Pressure Roller Thrust Spring	1				
13	CA08104A	Head Base Ass'y D	1				
14	0C08182A	Pressure Roller Drive Bar B	1				
15	0C08086B	Head Base Roller	3				
16	0C08050B	Record Sensor	1				
17	0C08051E	Cassette Hold Arm	1				
18	0C08120A	Cassette Hold Arm Spring	1				
19	CA08027A	Head Base Drive Arm Ass'y	1				
20	0C08143C	Head Base Drive Arm Spring	1				
21	CA08025A	Record Arm Ass'y	1				
22	0C08038A	Record Trigger	1				
23	0C08112A	Flip-Flop Spring	1				
24	CA08026A	Pressure Roller Drive Arm Ass'y	1				
25	CA08099A	Auto Shut-off Ass'y	1				
26	CA08098A	Counter Ass'y	1				
27	CA08105A	Pitch Control Holder Ass'y	1				
28	0C08224A	Counter Belt	1				
29	0C08119A	Record Protector	1				
30	0C08194C	Damper Lock Arm	1				
31	0C08153A	Damper Lock Arm Spring Tube	1				
32	0C08125A	Damper Lock Arm Spring	1				
33	CA08030A	Pneumatic Damper Ass'y	1				
34	CA08023A	Supply Capstan Flange Ass'y	1				
35	CA08024A	Take-up Capstan Flange Ass'y	1				
36	0C08186A	Cam Drive Gear	1				
37	0C08029H	Control Cam	1				
38	0C08152A	Counter-Load Arm Spring	1				
39	0C08117A	Counter-Load Arm Spring Tube	1				
40	CA08028A	Counter-Load Arm Ass'y	1				
41	0C08123B	Record Switch Linkage Wire	1				
42	0C08037E	Record Arm B	1				
43	0C08116A	Record Arm Spring	1				
44	CA08072A	Main Chassis Ass'y	1				
45	0C08250A	Supply Pressure Roller Spring B	1				
46	CA08196A	Back Tension Ass'y	1				
47	0C08254A	Back Tension Arm Collar	1				
L01	0E00837A	Stopper Ring 3mm	12				
L02	0E00832A	BT Screw M3x14 Philips Pan Head	2				
L03	0E00834A	BT Screw M3x30 Philips Pan Head	2				
L04	0E00831A	BT Screw M3x10 Philips Pan Head	3				
L05	0E00254A	Washer 3.1mm (Plastics)	2				
L06	0E00222A	E-Ring 2mm	2				
L07	0E00839A	Stopper Ring 2.5mm	1				
L08	0E00876A	Screw M2.6x8 Philips Pan Head	11				
L09	0C08060B	Height Adjustment Nut	2				
L10	0E00142A	Washer 2.6mm	2				



8.9. Main Mechanism Chassis Ass'y (C03)

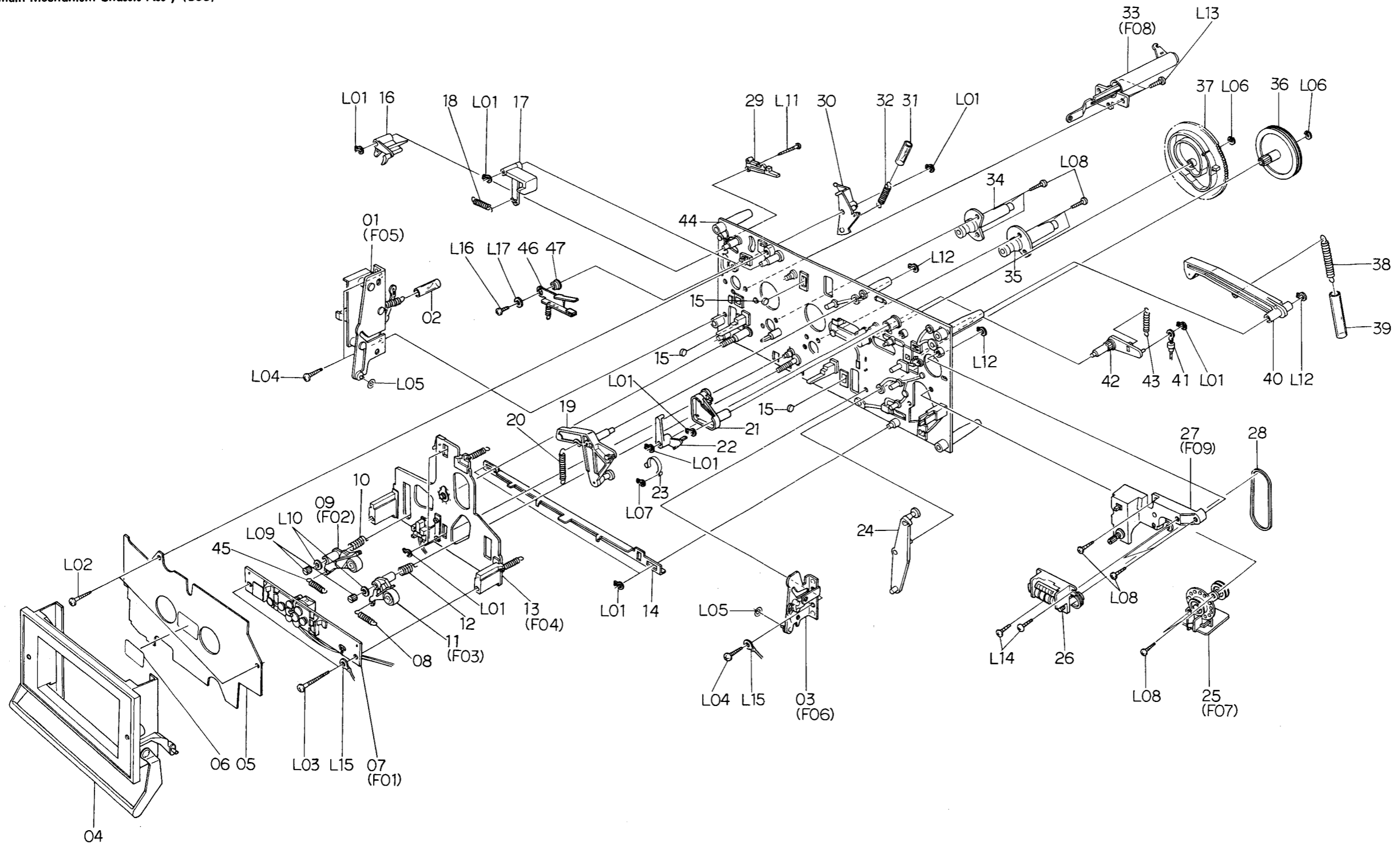

Fig. 8.9.1 Serial No.: A30704141 -

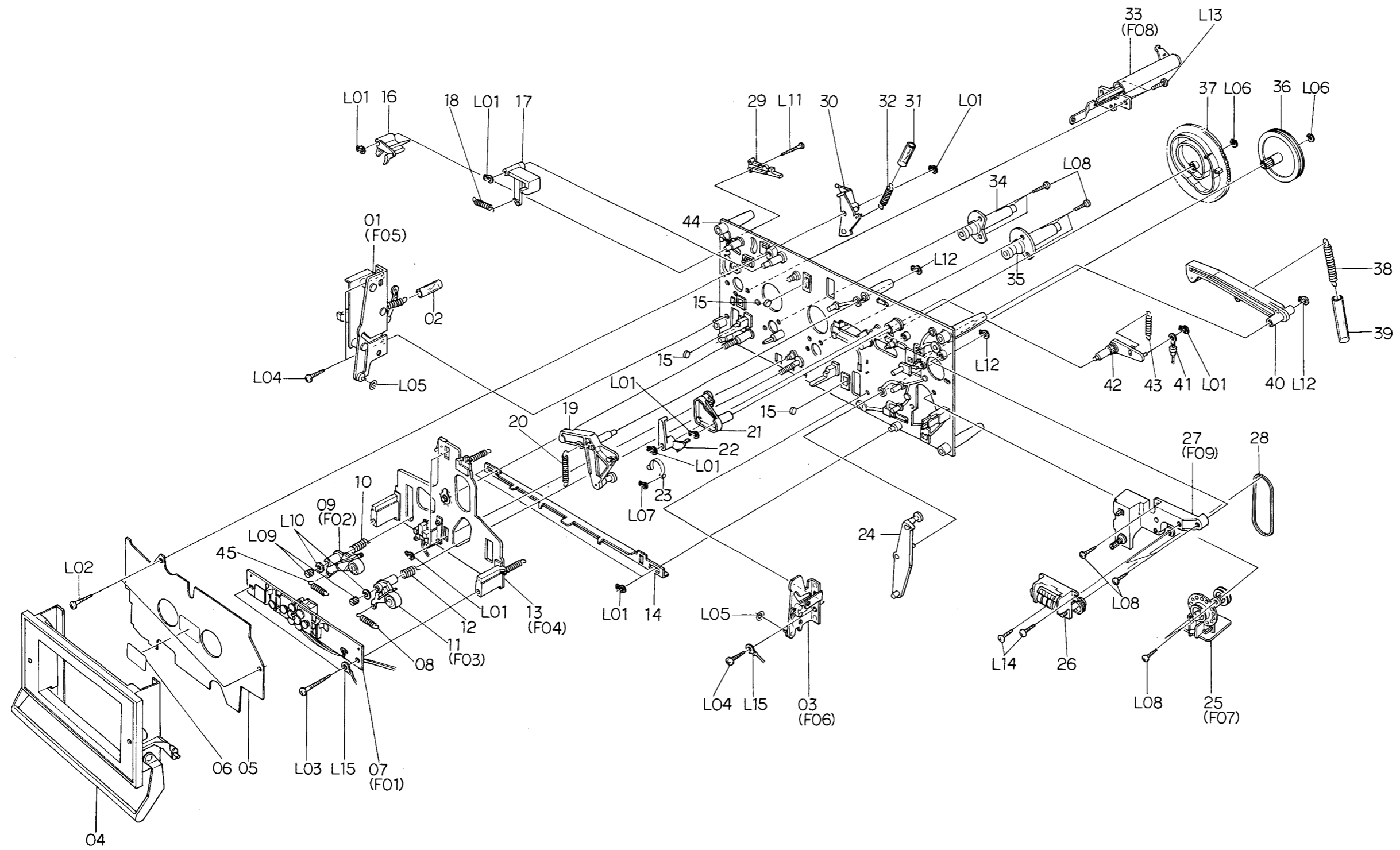

Fig. 8.9.2 Serial Nos.: A30703405 – A30704140

Schematic Ref. No.	Part No.	Description	Q'ty	Schematic Ref. No.	Part No.	Description	Q'ty
C03	CA08179A	Main Mechanism Chassis Ass'y Serial Nos.: A30703405 — A30704140	1	L11	0E00879A	BT Screw M2x15 Philips Pan Head	1
				L12	0E00838A	Stopper Ring 4mm	3
				L13	0E00846A	BT Screw M3x8 Philips Pan Head	3
				L14	0E00865A	BT Screw M3x10 Philips Binding Head	2
01	CA08125A	Cassette Case Holder L Ass'y	1	L15	0E00895A	Earth Lug 3mm	2
02	0C08151A	Lid Arm Spring Tube	1				
03	CA08022A	Cassette Case Holder R Ass'y	1				
04	CA08163A	Cassette Case Ass'y	1				
05	0C08019I	Cover Plate	1				
06	0M03977A	Cassette Viewer Label	1				
07	CA08147A	Head Mount Base Ass'y	1				
08	0C08121A	Supply Pressure Roller Spring	1				
09	CA08053B	Supply Pressure Roller Ass'y	1				
10	0C08122B	Supply Pressure Roller Thrust Spring	1				
11	CA08079B	Take-up Pressure Roller Ass'y	1				
12	0C08183B	Take-up Pressure Roller Thrust Spring	1				
13	CA08104A	Head Base Ass'y D	1				
14	0C08182A	Pressure Roller Drive Bar B	1				
15	0C08086B	Head Base Roller	3				
16	0C08050B	Record Sensor	1				
17	0C08051E	Cassette Hold Arm	1				
18	0C08120A	Cassette Hold Arm Spring	1				
19	CA08027A	Head Base Drive Arm Ass'y	1				
20	0C08143C	Head Base Drive Arm Spring	1				
21	CA08025A	Record Arm Ass'y	1				
22	0C08038A	Record Trigger	1				
23	0C08112A	Flip-Flop Spring	1				
24	CA08026A	Pressure Roller Drive Arm Ass'y	1				
25	CA08099A	Auto Shut-off Ass'y	1				
26	CA08098A	Counter Ass'y	1				
27	CA08105A	Pitch Control Holder Ass'y	1				
28	0C08224A	Counter Belt	1				
29	0C08119A	Record Protector	1				
30	0C08194C	Damper Lock Arm	1				
31	0C08153A	Damper Lock Arm Spring Tube	1				
32	0C08125A	Damper Lock Arm Spring	1				
33	CA08030A	Pneumatic Damper Ass'y	1				
34	CA08023A	Supply Capstan Flange Ass'y	1				
35	CA08024A	Take-up Capstan Flange Ass'y	1				
36	0C08186A	Cam Drive Gear	1				
37	0C08029H	Control Cam	1				
38	0C08152A	Counter-Load Arm Spring	1				
39	0C08117A	Counter-Load Arm Spring Tube	1				
40	CA08028A	Counter-Load Arm Ass'y	1				
41	0C08123B	Record Switch Linkage Wire	1				
42	0C08037E	Record Arm B	1				
43	0C08116A	Record Arm Spring	1				
44	CA08072A	Main Chassis Ass'y	1				
45	0C08250A	Supply Pressure Roller Spring B	1				
L01	0E00837A	Stopper Ring 3mm	12				
L02	0E00832A	BT Screw M3x14 Philips Pan Head	2				
L03	0E00834A	BT Screw M3x30 Philips Pan Head	2				
L04	0E00831A	BT Screw M3x10 Philips Pan Head	3				
L05	0E00254A	Washer 3.1mm (Plastics)	2				
L06	0E00222A	E-Ring 2mm	2				
L07	0E00839A	Stopper Ring 2.5mm	1				
L08	0E00876A	Screw M2.6x8 Philips Pan Head	11				
L09	0C08060B	Height Adjustment Nut	2				
L10	0E00142A	Washer 2.6mm	2				

Schematic Ref. No.	Part No.	Description	Q'ty	Schematic Ref. No.	Part No.	Description	Q'ty			
C03	CA08153A	Main Mechanism Chassis Ass'y Serial Nos.: A30702751 – A30703404	1	L14	0E00865A	BT Screw M3x10 Philips Binding Head	2			
				L15	0E00895A	Earth Lug 3mm	2			
01	CA08125A	Cassette Case Holder L Ass'y	1	C03	CA08153A	Main Mechanism Chassis Ass'y Serial Nos.: A30701001 – A30702750	1			
02	0C08151A	Lid Arm Spring Tube	1				01	CA08125A	Cassette Case Holder L Ass'y	1
03	CA08022A	Cassette Case Holder R Ass'y	1				02	0C08151A	Lid Arm Spring Tube	1
04	CA08163A	Cassette Case Ass'y	1				03	CA08022A	Cassette Case Holder R Ass'y	1
05	0C08019I	Cover Plate	1				04	CA08163A	Cassette Case Ass'y	1
06	0M03977A	Cassette Viewer Label	1				05	0C08019I	Cover Plate	1
07	CA08147A	Head Mount Base Ass'y	1				06	0M03977A	Cassette Viewer Label	1
08	0C08121A	Supply Pressure Roller Spring	2				07	CA08147A	Head Mount Base Ass'y	1
09	CA08053B	Supply Pressure Roller Ass'y	1				08	0C08121A	Supply Pressure Roller Spring	2
10	0C08122B	Supply Pressure Roller Thrust Spring	1				09	CA08053B	Supply Pressure Roller Ass'y	1
11	CA08079B	Take-up Pressure Roller Ass'y	1				10	0C08122B	Supply Pressure Roller Thrust Spring	1
12	0C08183B	Take-up Pressure Roller Thrust Spring	1				11	CA08079A	Take-up Pressure Roller Ass'y	1
13	CA08104A	Head Base Ass'y D	1				12	0C08183B	Take-up Pressure Roller Thrust Spring	1
14	0C08182A	Pressure Roller Drive Bar B	1	13	CA08104A	Head Base Ass'y D	1			
15	0C08086B	Head Base Roller	3	14	0C08182A	Pressure Roller Drive Bar B	1			
16	0C08050B	Record Sensor	1	15	0C08086B	Head Base Roller	3			
17	0C08051E	Cassette Hold Arm	1	16	0C08050B	Record Sensor	1			
18	0C08120A	Cassette Hold Arm Spring	1	17	0C08051E	Cassette Hold Arm	1			
19	CA08027A	Head Base Drive Arm Ass'y	1	18	0C08120A	Cassette Hold Arm Spring	1			
20	0C08143C	Head Base Drive Arm Spring	1	19	CA08027A	Head Base Drive Arm Ass'y	1			
21	CA08025A	Record Arm Ass'y	1	20	0C08143C	Head Base Drive Arm Spring	1			
22	0C08038A	Record Trigger	1	21	CA08025A	Record Arm Ass'y	1			
23	0C08112A	Flip-Flop Spring	1	22	0C08038A	Record Trigger	1			
24	CA08026A	Pressure Roller Drive Arm Ass'y	1	23	0C08112A	Flip-Flop Spring	1			
25	CA08099A	Auto Shut-off Ass'y	1	24	CA08026A	Pressure Roller Drive Arm Ass'y	1			
26	CA08098A	Counter Ass'y	1	25	CA08099A	Auto Shut-off Ass'y	1			
27	CA08105A	Pitch Control Holder Ass'y	1	26	CA08098A	Counter Ass'y	1			
28	0C08224A	Counter Belt	1	27	CA08105A	Pitch Control Holder Ass'y	1			
29	0C08119A	Record Protector	1	28	0C08224A	Counter Belt	1			
30	0C08194C	Damper Lock Arm	1	29	0C08119A	Record Protector	1			
31	0C08153A	Damper Lock Arm Spring Tube	1	30	0C08194C	Damper Lock Arm	1			
32	0C08125A	Damper Lock Arm Spring	1	31	QC08153A	Damper Lock Arm Spring Tube	1			
33	CA08030A	Pneumatic Damper Ass'y	1	32	0C08125A	Damper Lock Arm Spring	1			
34	CA08023A	Supply Capstan Flange Ass'y	1	33	CA08030A	Pneumatic Damper Ass'y	1			
35	CA08024A	Take-up Capstan Flange Ass'y	1	34	CA08023A	Supply Capstan Flange Ass'y	1			
36	0C08186A	Cam Drive Gear	1	35	CA08024A	Take-up Capstan Flange Ass'y	1			
37	0C08029H	Control Cam	1	36	0C08186A	Cam Drive Gear	1			
38	0C08152A	Counter-Load Arm Spring	1	37	0C08029H	Control Cam	1			
39	0C08117A	Counter-Load Arm Spring Tube	1	38	0C08152A	Counter-Load Arm Spring	1			
40	CA08028A	Counter-Load Arm Ass'y	1	39	0C08117A	Counter-Load Arm Spring Tube	1			
41	0C08123B	Record Switch Linkage Wire	1	40	CA08028A	Counter-Load Arm Ass'y	1			
42	0C08037E	Record Arm B	1	41	0C08123B	Record Switch Linkage Wire	1			
43	0C08116A	Record Arm Spring	1	42	0C08037E	Record Arm B	1			
44	CA08072A	Main Chassis Ass'y	1	43	0C08116A	Record Arm Spring	1			
L01	0E00837A	Stopper Ring 3mm	12	44	CA08072A	Main Chassis Ass'y	1			
L02	0E00832A	BT Screw M3x14 Philips Pan Head	2	L01	0E00837A	Stopper Ring 3mm	12			
L03	0E00834A	BT Screw M3x30 Philips Pan Head	2	L02	0E00832A	BT Screw M3x14 Philips Pan Head	2			
L04	0E00831A	BT Screw M3x10 Philips Pan Head	3	L03	0E00834A	BT Screw M3x30 Philips Pan Head	2			
L05	0E00254A	Washer 3.1mm (Plastics)	2	L04	0E00831A	BT Screw M3x10 Philips Pan Head	3			
L06	0E00222A	E-Ring 2mm	2	L05	0E00254A	Washer 3.1mm (Plastics)	2			
L07	0E00839A	Stopper Ring 2.5mm	1	L06	0E00222A	E-Ring 2mm	2			
L08	0E00876A	Screw M2.6x8 Philips Pan Head	11	L07	0E00839A	Stopper Ring 2.5mm	1			
L09	0C08060B	Height Adjustment Nut	2	L08	0E00876A	Screw M2.6x8 Philips Pan Head	11			
L10	0E00142A	Washer 2.6mm	2	L09	0C08060B	Height Adjustment Nut	2			
L11	0E00879A	BT Screw M2x15 Philips Pan Head	1							
L12	0E00838A	Stopper Ring 4mm	3							
L13	0E00846A	BT Screw M3x8 Philips Pan Head	3							

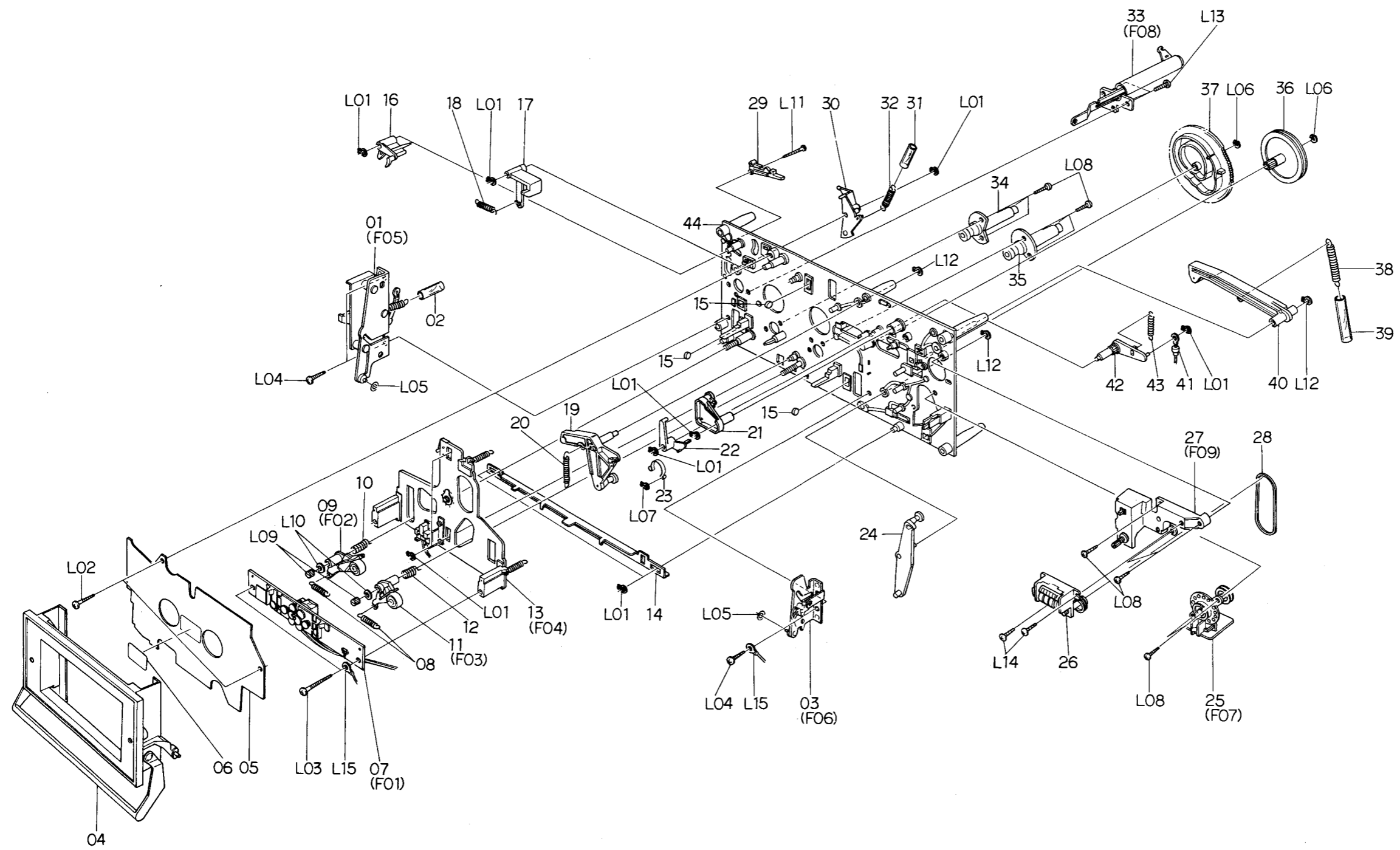

Fig. 8.9.3 Serial Nos.: A30701001 – A30703404

Schematic Ref. No.	Part No.	Description	Q'ty
L10	0E00142A	Washer 2.6mm	2
L11	0E00879A	BT Screw M2x15 Philips Pan Head	1
L12	0E00838A	Stopper Ring 4mm	3
L13	0E00846A	BT Screw M3x8 Philips Pan Head	3
L14	0E00865A	BT Screw M3x10 Philips Binding Head	2
L15	0E00895A	Earth Lug 3mm	2

8.10. Record Calibration Ass'y (D01)

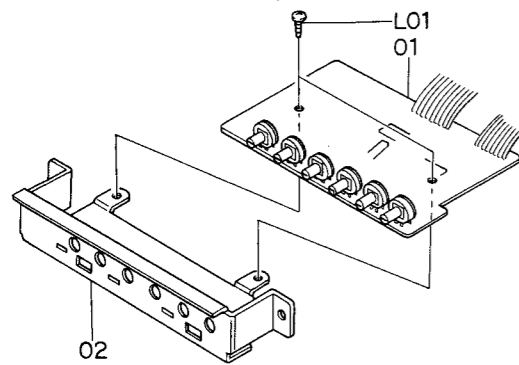

Fig. 8.10

8.11. Volume Holder Ass'y (D02)

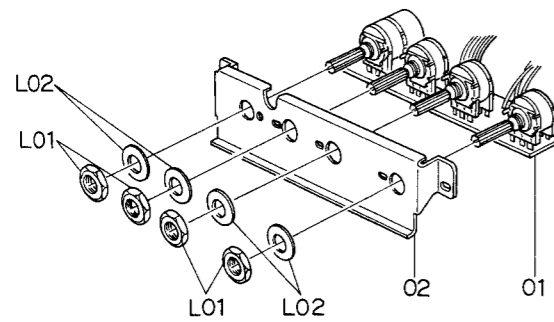

Fig. 8.11

8.12. Headphone Jack Ass'y (D03)

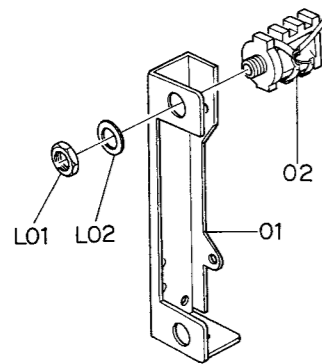

Fig. 8.12

8.13. Reflector Ass'y (D04)

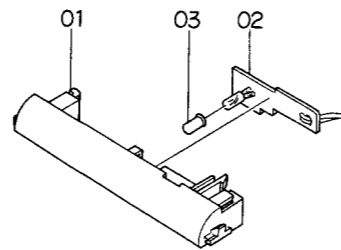

Fig. 8.13

8.14. Counter Lamp Ass'y (D05)

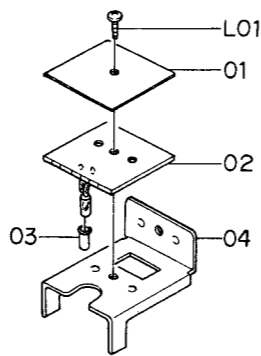

Fig. 8.14

8.15. Power Switch Holder Ass'y (D06)

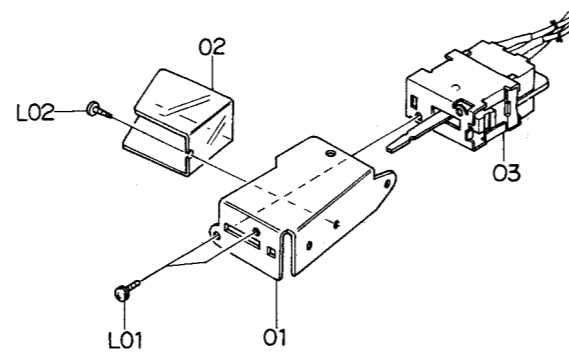

Fig. 8.15

Schematic Ref. No.	Part No.	Description	Q'ty	Schematic Ref. No.	Part No.	Description	Q'ty
D01	JA03661A	Record Calibration Ass'y Serial No.: A30701001 -	1	D07	HA03945A	Rear Panel Ass'y (U.S.A. & Canada)	1
01	BA04188A	Record Cal. P.C.B. Ass'y	1		HA03946A	Rear Panel Ass'y (Japan)	1
02	0J04102B	Cal. P.C.B. Holder	1		HA03950A	Rear Panel Ass'y (220V Class 2)	1
L01	0E00856A	BT Screw M3x5 Philips Binding Head	2		HA03949A	Rear Panel Ass'y (Australia)	1
					HA03948A	Rear Panel Ass'y (UK)	1
					HA03947A	Rear Panel Ass'y (Others)	1
						Serial No.: A30701001 -	
D02	JA03658A	Volume Holder Ass'y Serial No.: A30701001 -	1	01	0H03817A	Rear Panel	1
01	BA04175A	Volume P.C.B. Ass'y	1	02	BA04176A	Pin Jack P.C.B. Ass'y	1
02	0J04100A	Volume Holder	1	03	0B08355A	4P DIN Socket	1
L01	-	Volume Nut	(4)	04	0B08584A	8P DIN Socket	1
L02	-	Volume Washer	(4)	05	BA04202A	Fuse P.C.B. Ass'y (U.S.A. & Canada)	1
					BA04203A	Fuse P.C.B. Ass'y (Japan)	1
					BA04204A	Fuse P.C.B. Ass'y (220V Class 2)	1
					BA04205A	Fuse P.C.B. Ass'y (UK & Australia)	1
					BA04206A	Fuse P.C.B. Ass'y (Others)	1
D03	JA03659A	Headphone Jack Ass'y Serial No.: A30701001 -	1	06	OC01162B	Bolt Receptacle Plate	2
01	0J04101A	Headphone Jack Holder	1	07	0B06609B	Power Transformer (U.S.A. & Canada)	1
02	0B08511A	Headphone Jack	1		0B06610A	Power Transformer (Japan)	1
L01	-	Headphone Jack Nut	(1)		0B06612A	Power Transformer (220V Class 2, UK & Australia)	1
L02	-	Headphone Jack Washer	(1)		0B06611B	Power Transformer (Others)	1
				08	0J04016A	Transformer Plate	1
D04	JA03600A	Reflector Ass'y Serial No.: A30701001 -	1	09	0B08037U	Cord Bushing C (U.S.A., Canada, Japan, 220V Class 2 & Others)	1
01	0H03754C	Reflector	1		0B08719A	Cord Bushing (Australia)	1
02	BA04063A	Lamp P.C.B. C Ass'y	1	10	0B08351A	Cord Bushing 4K-4 (UK)	1
03	0J04107A	Filter Cap	1		0B08533A	Power Cord (U.S.A., Canada & Others)	1
					0B08219B	Power Cord (Japan)	1
D05	JA03602A	Counter Lamp Ass'y Serial No.: A30701001 -	1		0B08093A	Power Cord (220V Class 2)	1
01	0J04083A	Insulator	1		0B08666A	Power Cord (Australia)	1
02	BA04062A	Lamp P.C.B. B Ass'y	1		0B08348A	Power Cord (UK)	1
03	0J04107A	Filter Cap	1	11	0A03154B	Cord Spacer	1
04	0J04041A	Counter Lamp P.C.B. Holder	1	12	0J03663A	Switch Cover (U.S.A., Canada, Japan, 220V Class 2, Australia & UK)	1
L01	0E00859A	BT Screw M2.6x6 Philips Binding Head	1		0M03946A	Voltage Selector Lock Plate C (Others)	1
				* 13	0B07092U	Voltage Selector (Others)	1
D06	JA03592A	Power Switch Holder Ass'y (U.S.A. & Canada)	1	14	0J04079A	Cushion B	3
	JA03595A	Power Switch Holder Ass'y (Japan)	1	15	0M03458B	Pass Label	1
	JA03594A	Power Switch Holder Ass'y (220V Class 2, UK, Australia & Others)	1	* 16	0M04075A	Fuse Caution Label (U.S.A. & Canada)	1
		Serial No.: A30701001 -			0M03794A	Voltage Label 100V (Japan)	1
01	0J04038A	Power Switch Holder	1		0M03796A	Voltage Label 220V (220V Class 2)	1
02	0J04056A	Power Switch Insulator	1		0M03797A	Voltage Label 240V (UK & Australia)	1
03	0B07280A	Power Switch (U.S.A. & Canada)	1		0M03955A	Voltage Label 120V/220V-240V (Others)	1
	0B07291A	Power Switch (Japan)	1	* -	0M03844B	Power Cord Label (UK)	1
	0B07292A	Power Switch (220V Class 2, UK, Australia & Others)	1	-	0F01071A	Free-up Belt	1
L01	0E00622A	Screw M3x5 Philips Pan Head (2A)	2	-	0M04115A	Serial Number Plate	1
L02	0E00873A	BT Screw M2.6x5 Philips Binding Head	1	L01	0B08720A	Plastic Rivet	4
				L02	0E00594A	Screw M3x8 Philips Binding Head (Bronze)	3
				* L03	0E00507A	Nut Hex. M3	3

8.16. Rear Panel Ass'y (D07)

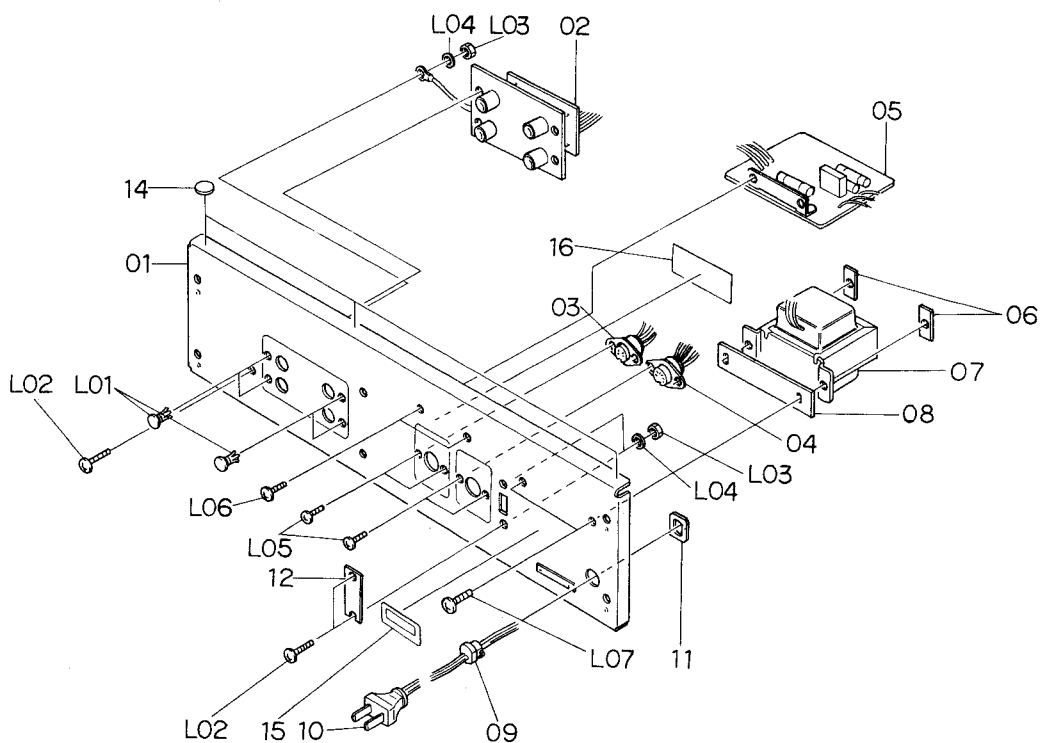
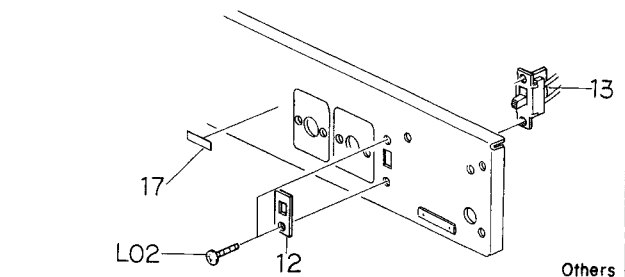

Fig. 8.16

Schematic Ref. No.	Part No.	Description	Q'ty
* L04	0E00581A	Washer 3mm (Spring)	3
L05	0E00714A	Screw M2.6x6 Philips Binding Head (Bronze)	4
L06	0E00593A	Screw M3x6 Philips Binding Head (Bronze)	2
L07	0E00756A	Screw M4x8 Philips Binding Head (Bronze)	2
—	0J03644A	Chobert Rivet	2
*: Depends on the versions.			

Schematic Ref. No.	Part No.	Description	Q'ty	Schematic Ref. No.	Part No.	Description	Q'ty
<b>E01</b>	<b>CA08117B</b>	<b>Reel Motor Ass'y</b> Serial No.: A30701001 —	<b>1</b>	<b>F03</b>	<b>CA08079B</b>	<b>Take-up Pressure Roller Ass'y</b> Serial No.: A30702751 —	<b>1</b>
01	0C08218A	Reel Motor	1	01	0C08164F	Pressure Roller	1
02	0C08063F	Reel Motor Pulley	1	02	0C08181C	Take-up Tape Guide	1
<b>E02</b>	<b>CA08034A</b>	<b>Control Motor Ass'y</b> Serial No.: A30701001 —	<b>1</b>	03	CA08024A	Take-up Pressure Roller Arm Ass'y	1
01	0C08137A	Control Motor	1	L01	0E00042A	E-Ring 1.5mm	1
02	0C08064A	Control Motor Pulley	1	L02	0C08024A	Washer 2mm	2
03	0B09292A	Ceramic Capacitor 0.1μ 50V	1	L03	0E00788A	BT Screw M2x8 Philips Pan Head	1
04	0M03985A	Control Motor Label	1	<b>F03</b>	<b>CA08079A</b>	<b>Take-up Pressure Roller Ass'y</b> Serial Nos.: A30701001 — A30702750	<b>1</b>
05	0M03988A	Motor Seal B	1	01	0C08164F	Pressure Roller	1
<b>E03</b>	<b>CA08148A</b>	<b>Azimuth Alignment Motor Ass'y</b> Serial No.: A30701001 —	<b>1</b>	02	0C08181B	Take-up Tape Guide	1
01	CA08149A	Azimuth Motor Ass'y	1	03	CA08024A	Take-up Pressure Roller Arm Ass'y	1
02	0C08099B	Control Motor Belt	1	L01	0E00042A	E-Ring 1.5mm	1
03	0C08229B	Drive Pulley	1	L02	0C08024A	Washer 2mm	2
04	0C08230B	Drive Pulley Shaft	1	L03	0E00788A	BT Screw M2x8 Philips Pan Head	1
05	0C08231B	Drive Nut	1	<b>F04</b>	<b>CA08104A</b>	<b>Head Base Ass'y D</b> Serial No.: A30701001 —	<b>1</b>
06	0C08232C	Drive Bar	1	01	GA02083A	E-8LH Erase Head	1
07	0C08233G	Drive Unit Base	1	02	0C08158C	EH Hold Plate	1
L01	0E00226A	Screw M2.6x4 Philips Pan Head	2	03	0C08166A	EH Hold Plate Spring	1
L02	0E00837A	Stopper Ring 3mm	1	04	0C08174C	Cassette Hold Spring	1
<b>F01</b>	<b>CA08147A</b>	<b>Head Mount Base Ass'y</b> Serial No.: A30701001 —	<b>1</b>	05	CA08003P	Head Base Ass'y	1
01	0C08028C	Head Height Adjustment Gear	2	06	0C08175A	Head Base L Spring	3
02	0C08027E	Head Height Adjustment Screw	4	07	0B08649E	2P-H Connector	1
03	0C08026D	Azimuth Alignment Screw	2	L01	0E00889A	Screw M1.7x8 Philips Pan Head	2
04	0C08161B	Spring Stopper	2	L02	0E00909A	Screw M2x6 Philips Pan Head	3
05	0C08187B	Head Plate Spring	2	L03	0E00117A	Washer 2mm	3
06	0C08236A	Azimuth Alignment Wire Hold Plate	1	L04	0E00853A	BT Screw M2x3 Philips Pan Head	1
07	CA08083C	Head Mount Base Sub Ass'y	1	<b>F05</b>	<b>CA08125A</b>	<b>Cassette Case Holder L Ass'y</b> Serial No.: A30701001 —	<b>1</b>
08	CA08158A	P-8L Playback Head Ass'y	1	01	CA08090F	Cassette Case Holder L Sub Ass'y	1
09	0C08235A	Azimuth Alignment Plate	1	02	0C08073C	Lid Arm A	1
10	CA08150A	R-8L Record Head Ass'y	1	03	0C08195F	Eject Arm Holder	1
L01	0E00917A	BT Screw M2.6x5 Philips Pan Head	2	04	0C08196B	Eject Arm A	1
<b>F02</b>	<b>CA08053B</b>	<b>Supply Pressure Roller Ass'y</b> Serial No.: A30701001 —	<b>1</b>	05	0C08197C	Eject Arm B	1
01	0C08164F	Pressure Roller	1	06	0C08199B	Eject Arm Joint	1
02	0C08189B	Supply Tape Guide	1	07	0C08114A	Lid Arm Spring	1
03	CA08061A	Supply Pressure Roller Arm Ass'y	1	08	0C08211C	Eject Arm Spring	1
L01	0E00042A	E-Ring 1.5mm	1	L01	0E00837A	Stopper Ring 3mm	1
L02	0C08024A	Washer 2mm	2	L02	0E00838A	Stopper Ring 4mm	1
L03	0E00788A	BT Screw M2x8 Philips Pan Head	1	L03	0E00865A	BT Screw M3x10 Philips Binding Head	2
				<b>F06</b>	<b>CA08022A</b>	<b>Cassette Case Holder R Ass'y</b> Serial No.: A30701001 —	<b>1</b>
				01	0C08133A	Eject Sensor	1
				02	CA08044A	Cassette Case Holder R Sub Ass'y	1
				L01	0E00840A	BT Screw M2x8 Philips Pan Head	2



8.17. Reel Motor Ass'y (E01)

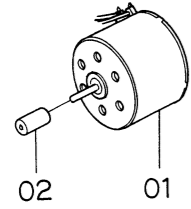

Fig. 8.17

8.18. Control Motor Ass'y (E02)

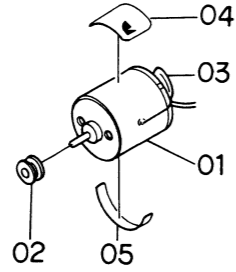

Fig. 8.18

8.19. Azimuth Alignment Motor Ass'y (E03)

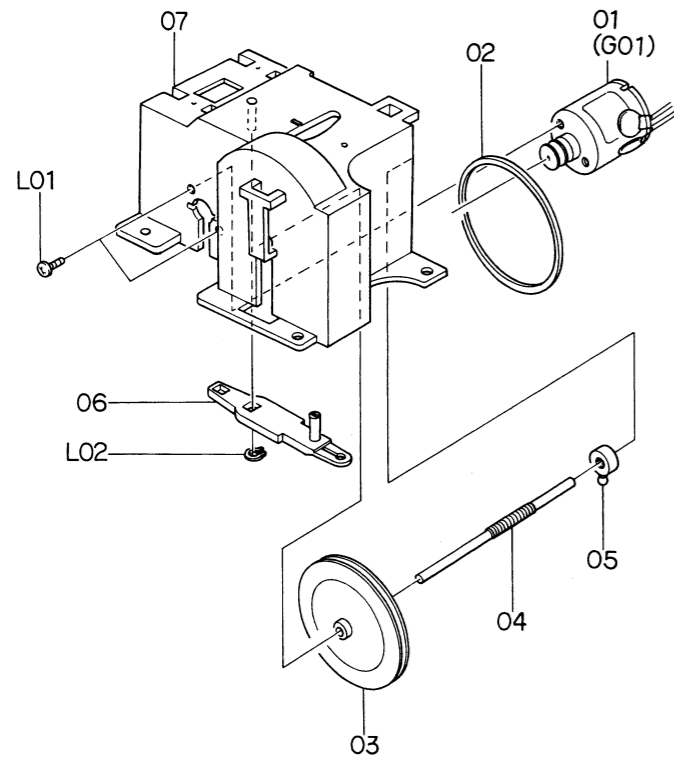

Fig. 8.19

8.20. Head Mount Base Ass'y (F01)

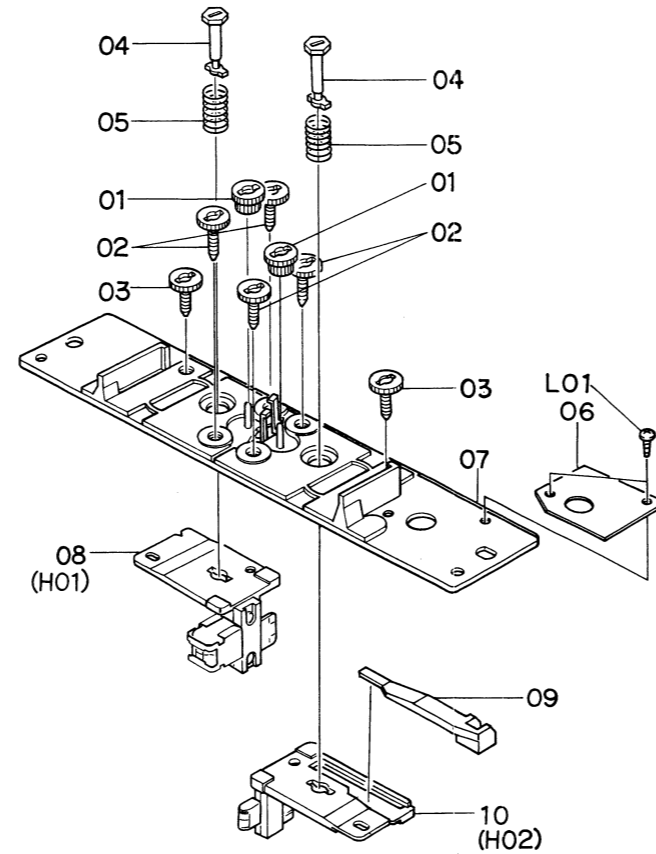

Fig. 8.20

8.21. Supply Pressure Roller Ass'y (F02)

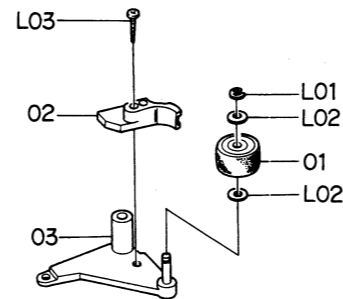

Fig. 8.21

8.22. Take-up Pressure Roller Ass'y (F03)

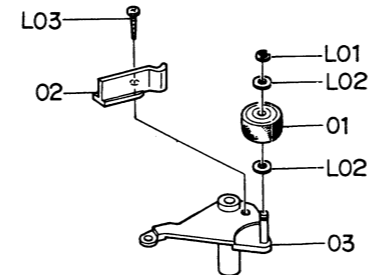

Fig. 8.22

8.23. Head Base Ass'y D (F04)

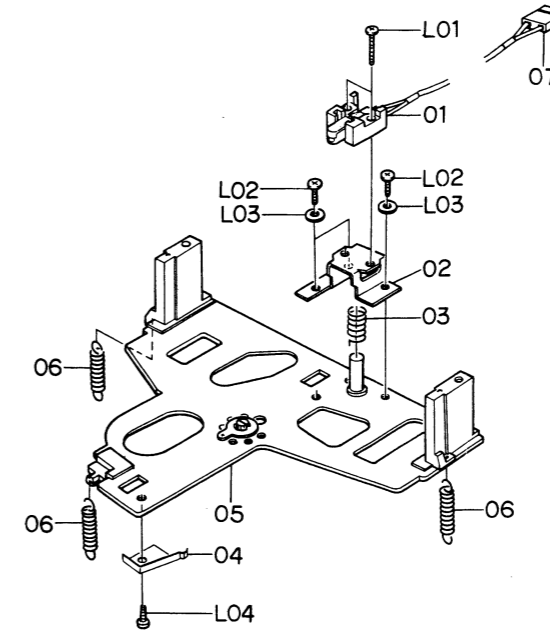

Fig. 8.23

8.24. Cassette Case Holder L Ass'y (F05)

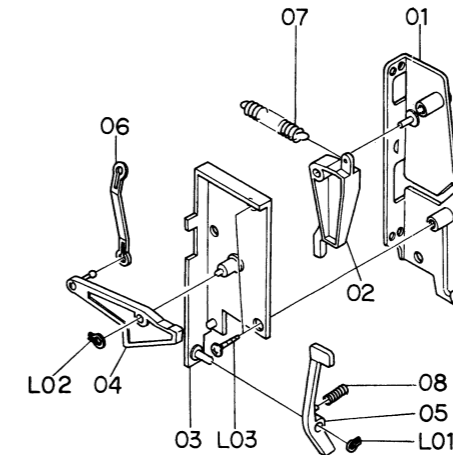

Fig. 8.24

8.25. Cassette Case Holder R Ass'y (F06)

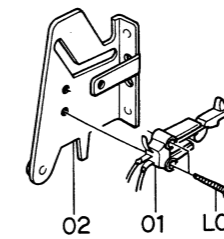

Fig. 8.25

Schematic Ref. No.	Part No.	Description	Q'ty
F07	CA08099A	Auto Shut-off Ass'y Serial No.: A30701001 -	1
01	0C08047A	Shut-off Pulley	2
02	0C08206B	Shut-off Pulley	1
03	0C08210A	Shut-off Pulley Shaft	1
04	0C08207B	Shut-off Pulley Holder	1
05	BA04070A	Shut-off P.C.B. Ass'y	1
F08	CA08030A	Pneumatic Damper Ass'y Serial No.: A30701001 -	1
01	0C08058C	Damper Piston	1
02	0C08102B	Damper Ring	1
03	0C08010C	Damper Plate	1
04	0C08059E	Sylinder	1
L01	0E00874A	Stopper Ring CS 2mm	1
F09	CA08105A	Pitch Control Holder Ass'y Serial No.: A30701001 -	1
01	0B07283A	Memory Switch	1
02	0B07282A	Volume Control 20kΩ (B)	1
03	0C08214D	Pitch Control Holder	1
L01	0E00125A	Screw M2x6 Philips Countersunk	2
L02	-	Volume Nut	(1)
L03	-	Volume Washer	(1)
G01	CA08149A	Azimuth Motor Ass'y Serial No.: A30701001 -	1
01	0C08137A	Control Motor	1
02	0C08064A	Control Motor Pulley	1
03	0B09292A	Ceramic Capacitor 0.1μ 50V Z	2
04	0M03985A	Motor Label 730	1
05	0M03988A	Motor Seal A	1
06	0B08708A	2P Connector	1
H01	CA08158A	P-8L Playback Head Ass'y Serial No.: A30701001 -	1
01	0C08160F	Head Plate	1
02	GA02034A	P-8L Playback Head	1
03	0C08169D	Pad Lifter 54	1
04	0B08647D	4P-H Connector	1
L01	0E00886A	Screw M1.7x6.5 Philips Pan Head	2
H02	CA08150A	R-8L Record Head Ass'y Serial No.: A30701001 -	1
01	0C08159G	Head Plate	1
02	GA01050A	R-8L Record Head	1
03	0B08648D	4P-H Connector	1
L01	0E00887A	Screw M1.7x4 Philips Pan Head	2

8.26. Auto Shut-off Ass'y (F07)

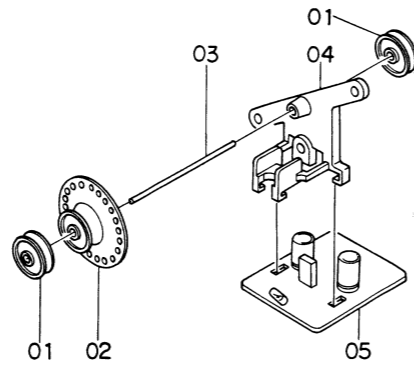

Fig. 8.26

8.27. Pneumatic Damper Ass'y (F08)

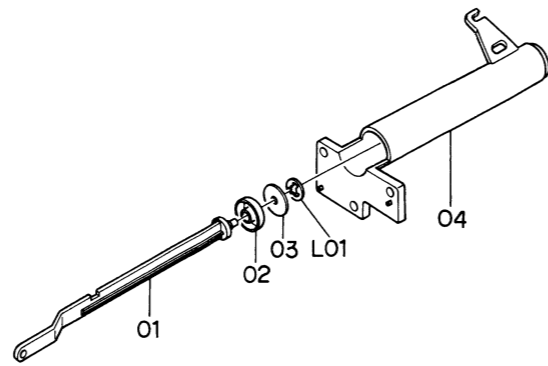

Fig. 8.27

8.28. Pitch Control Holder Ass'y (F09)

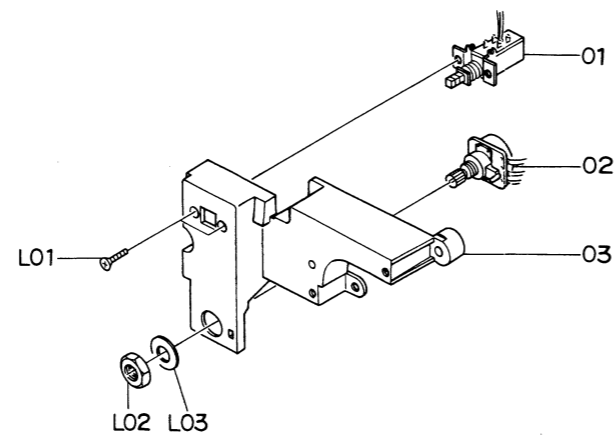

Fig. 8.28

8.29. Azimuth Motor Ass'y (G01)

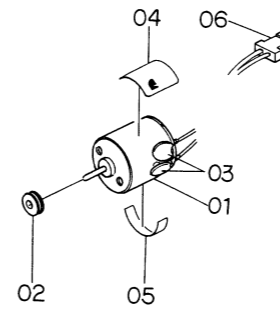

Fig. 8.29

8.30. P-8L Playback Head Ass'y (H01)

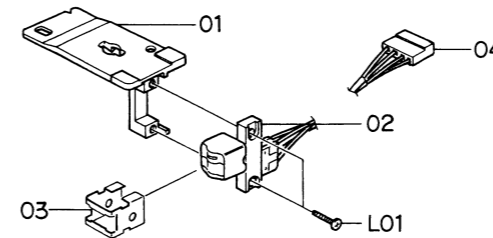

Fig. 8.30

8.31. R-8L Record Head Ass'y (H02)

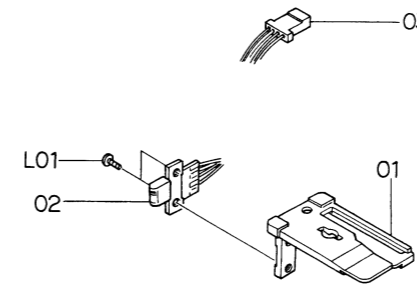

Fig. 8.31

9. OVERALL TIMING CHART

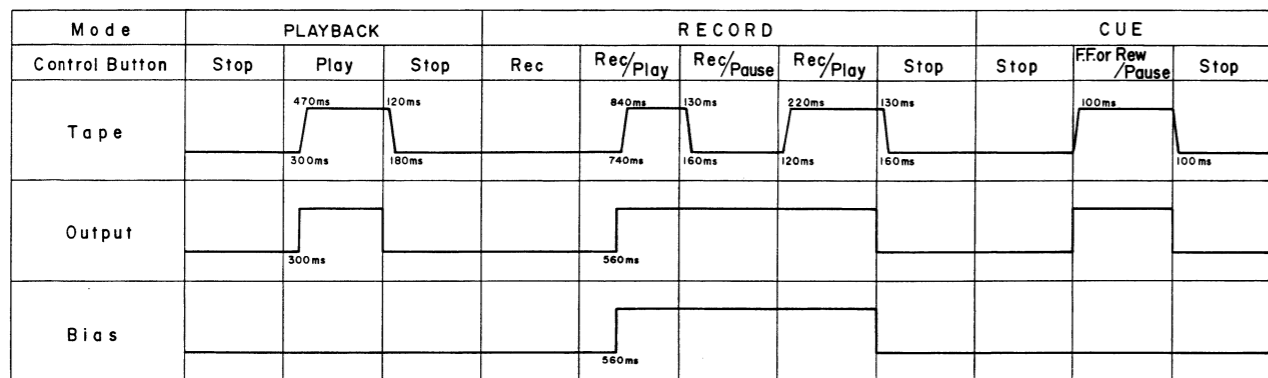

Fig. 9

10. EQ. AMP. FREQUENCY RESPONSE

10.1. Playback Frequency Response

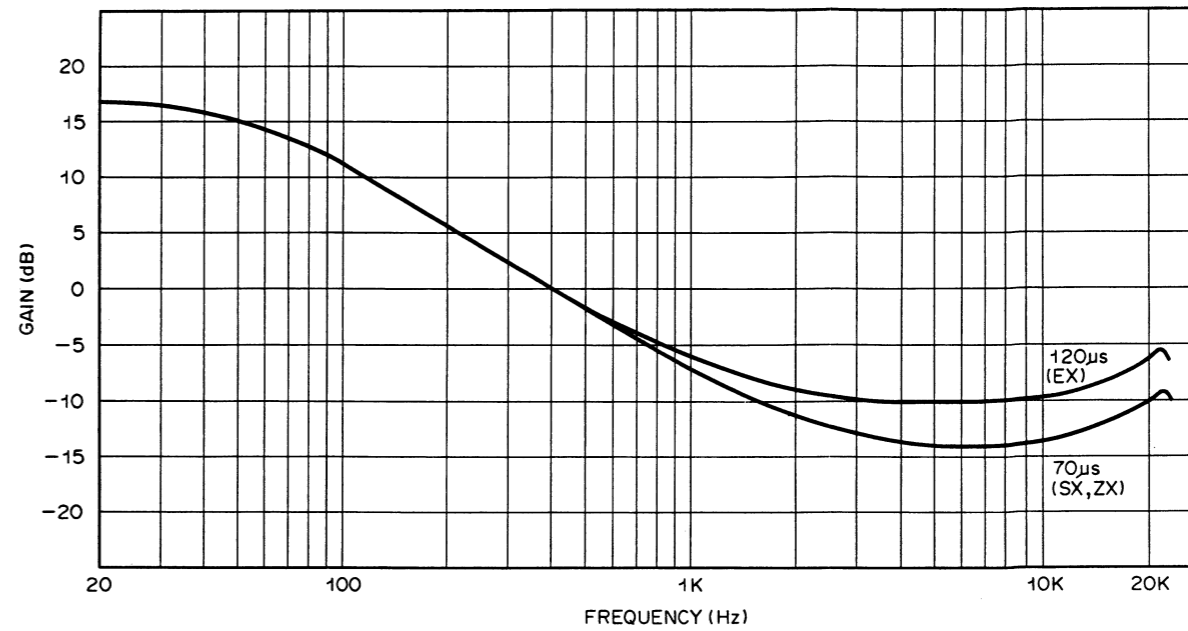

Fig. 10.1

10.2. Record Current Frequency Response

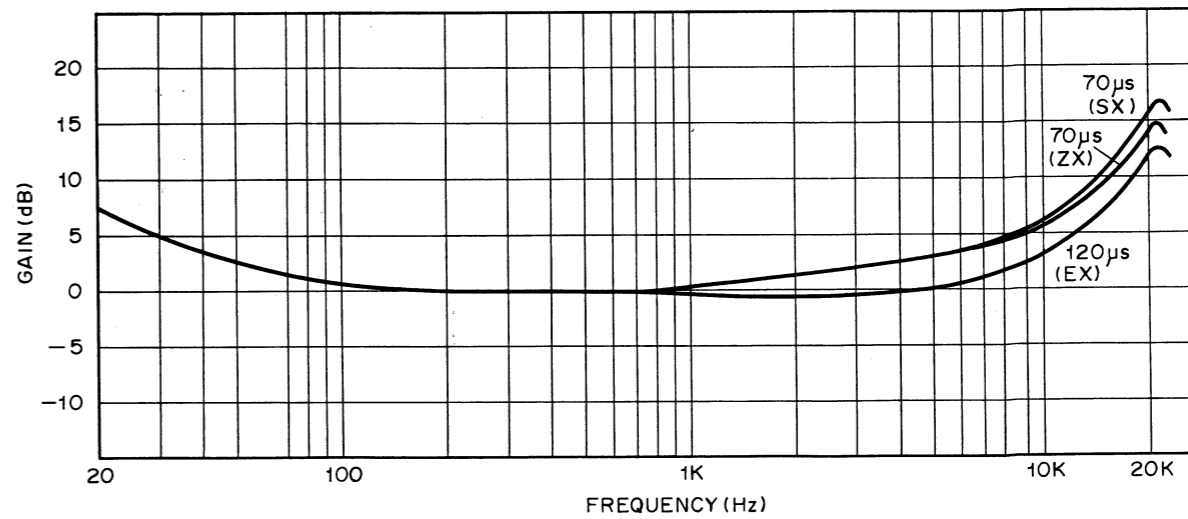

Fig. 10.2

11. BLOCK DIAGRAMS

11.1. Amplifier

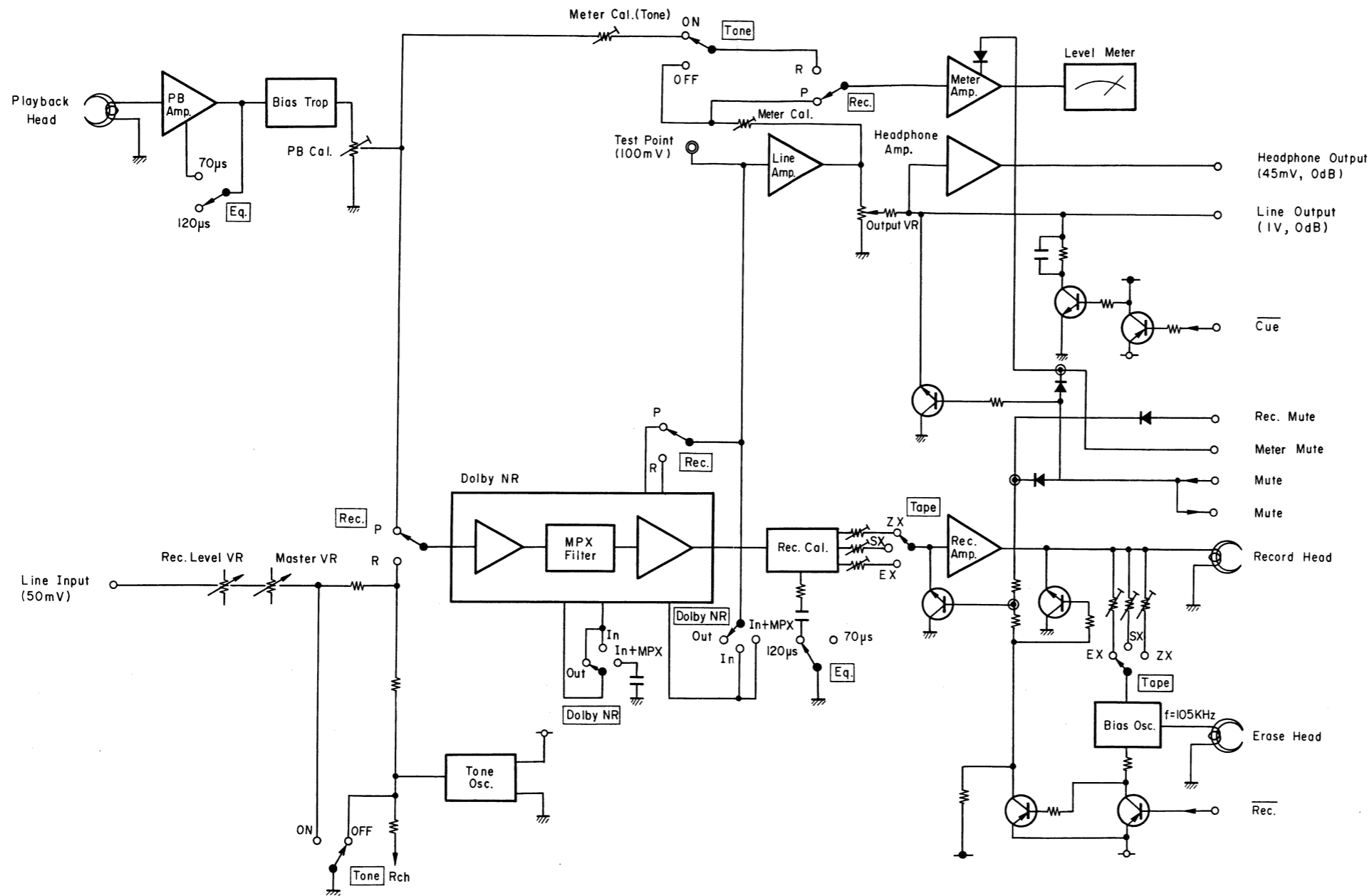

Fig. 11.1

11.2. Mechanism Control

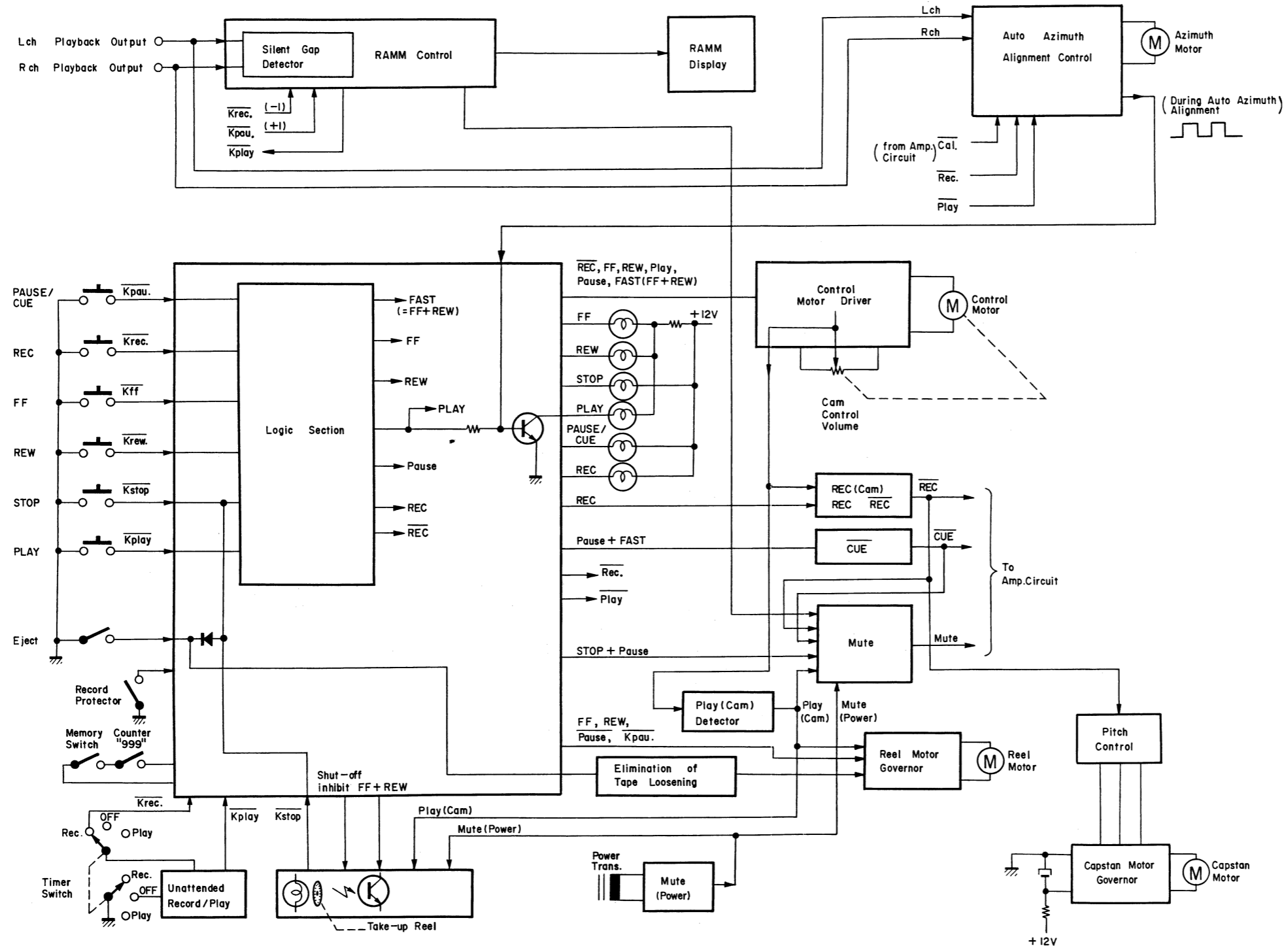

Fig. 11.2

12. WIRING DIAGRAM

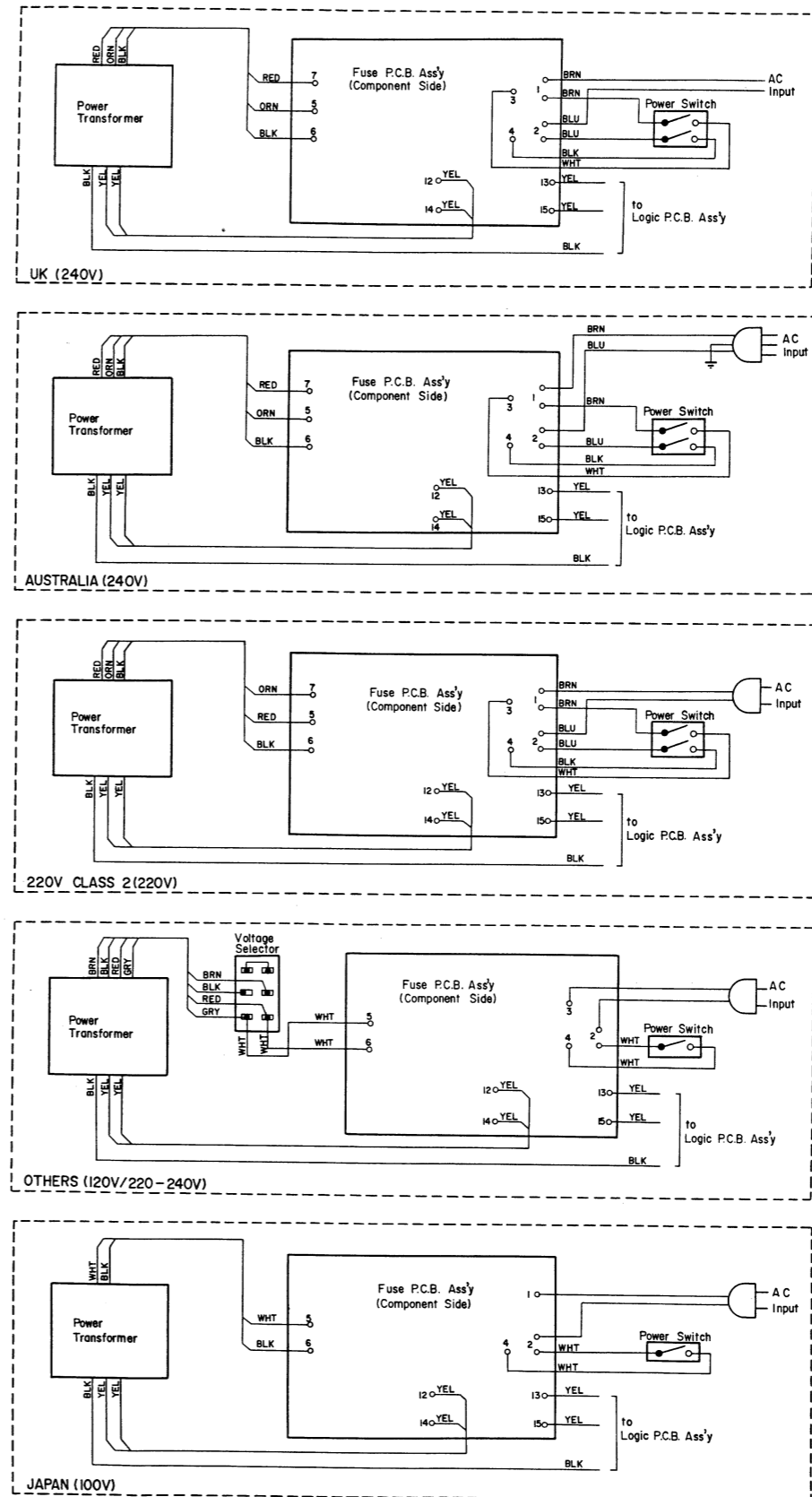
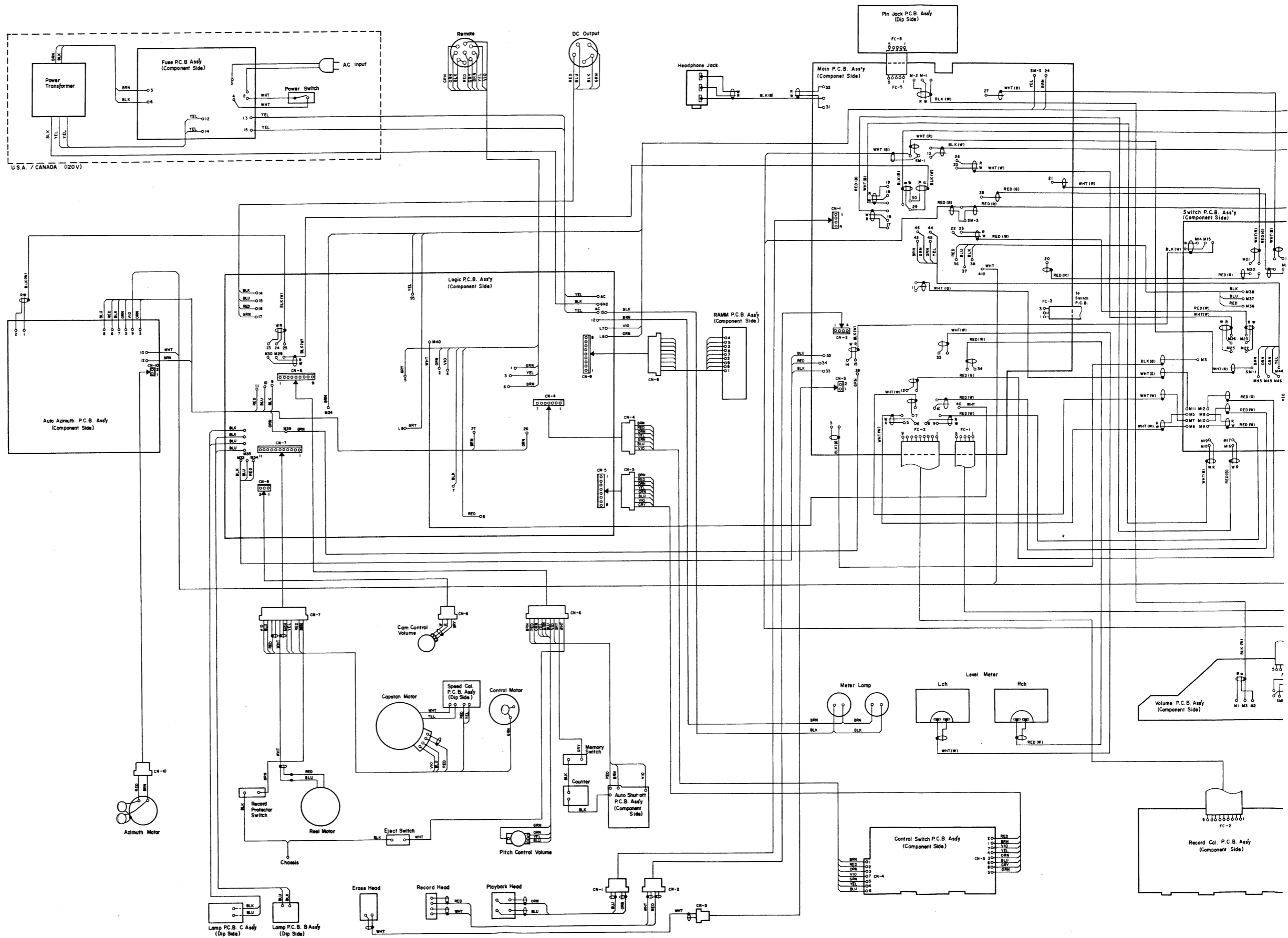

Fig. 12.1



Notes: 1. Table of wire colors

- BLK – Black
- BLU – Blue
- GRN – Green
- RED – Red
- WHT – White
- ORN – Orange
- GRY – Gray
- BRN – Brown
- YEL – Yellow
- VIO – Violet

2. Table of wire tube colors

- (B) – Black
- (R) – Red
- (W) – White
- (G) – Gray

Fig. 12.2

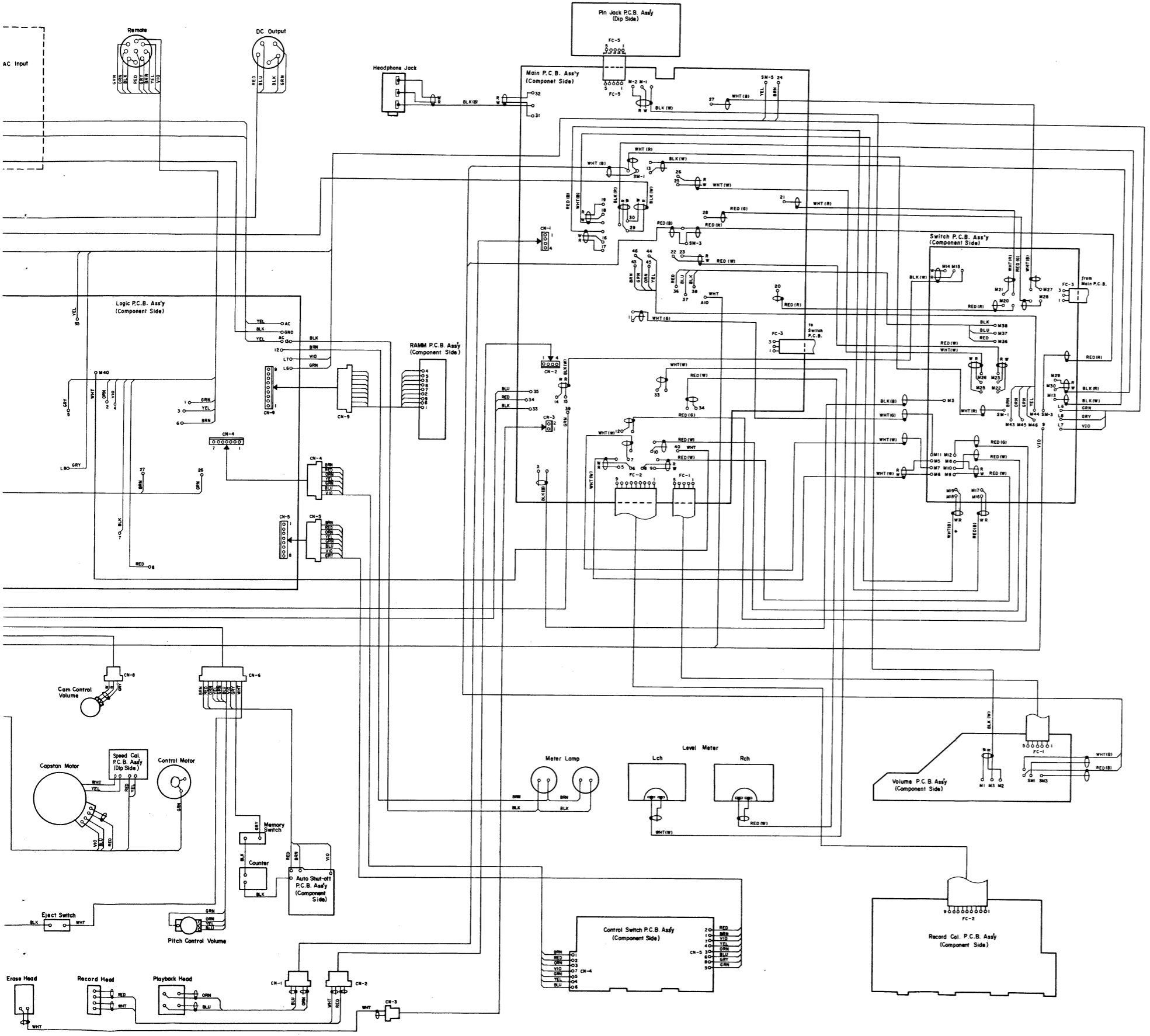

Fig. 12.2



13. SCHEMATIC DIAGRAMS

13.1. Amplifier

Notes:

1. Diode is 1SS53, 1S953, or 1S1555 unless otherwise specified.
2. Resistor and capacitor marked with \* show typical value.

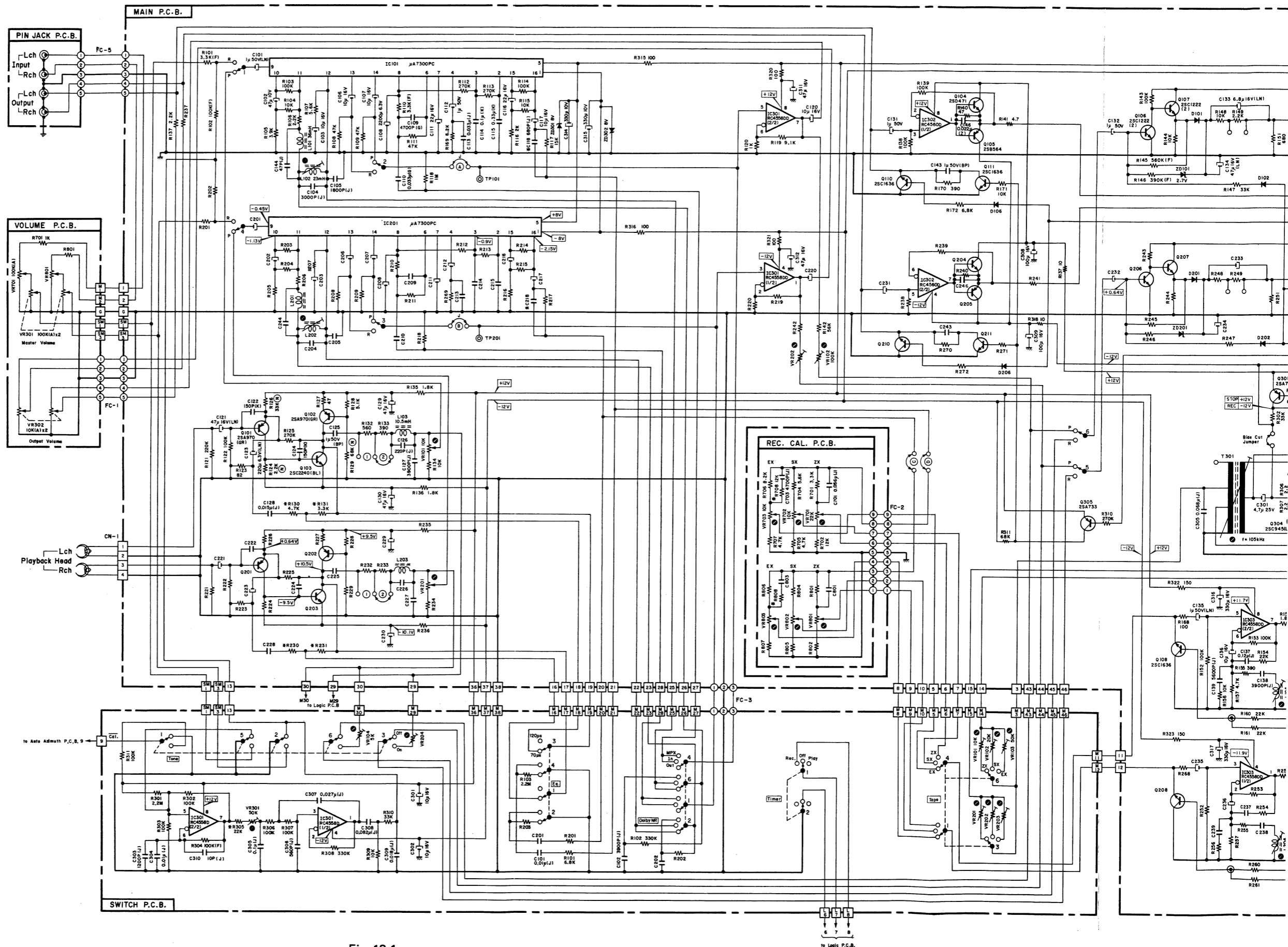
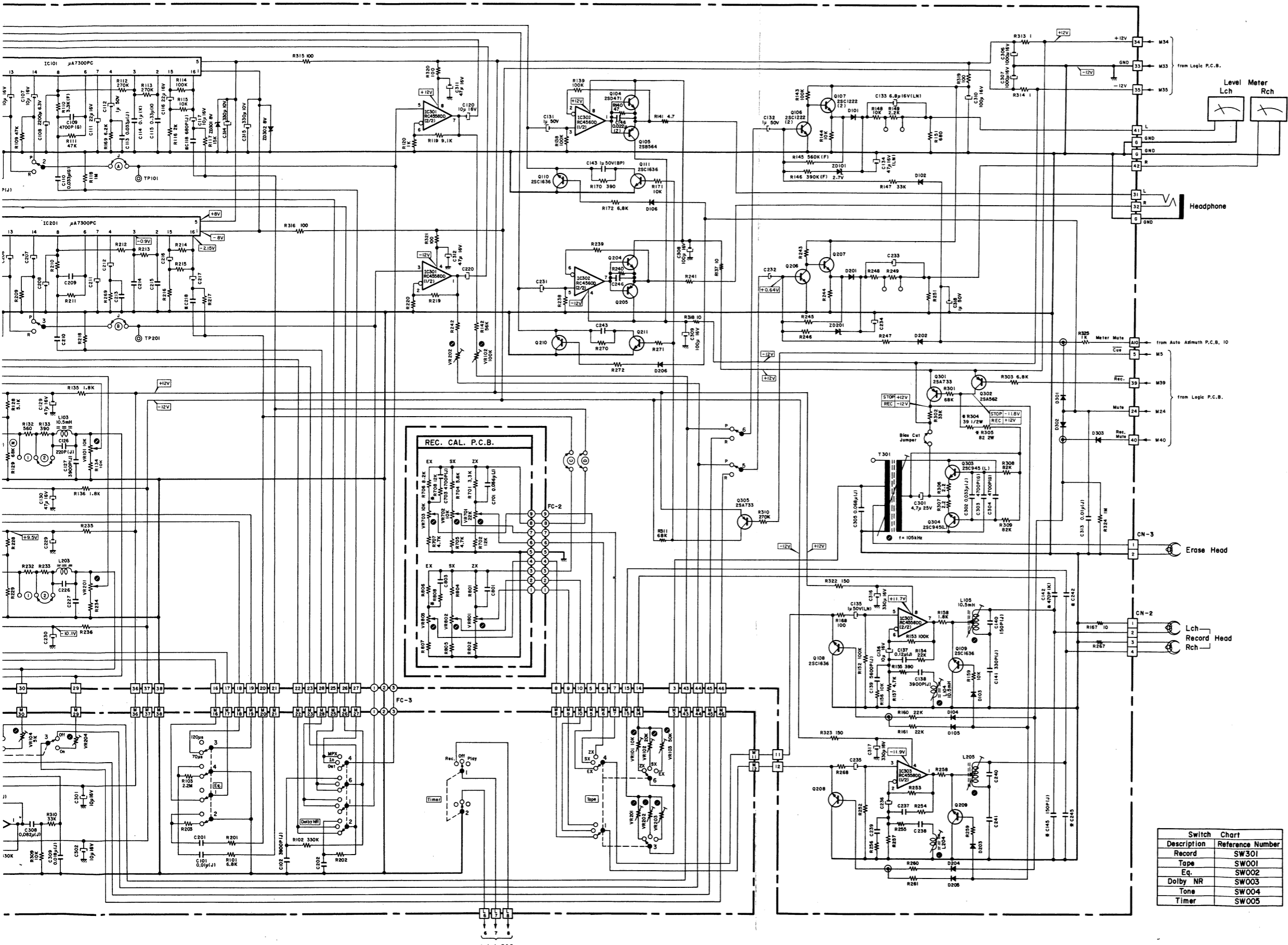

Fig. 13.1



Switch Chart	
Description	Reference Number
Record	SW301
Tape	SW001
Eq.	SW002
Dolby NR	SW003
Tone	SW004
Timer	SW005

Fig. 13.1

13.2. Mechanism Control

Notes: 1. Dioc  
2. Resi

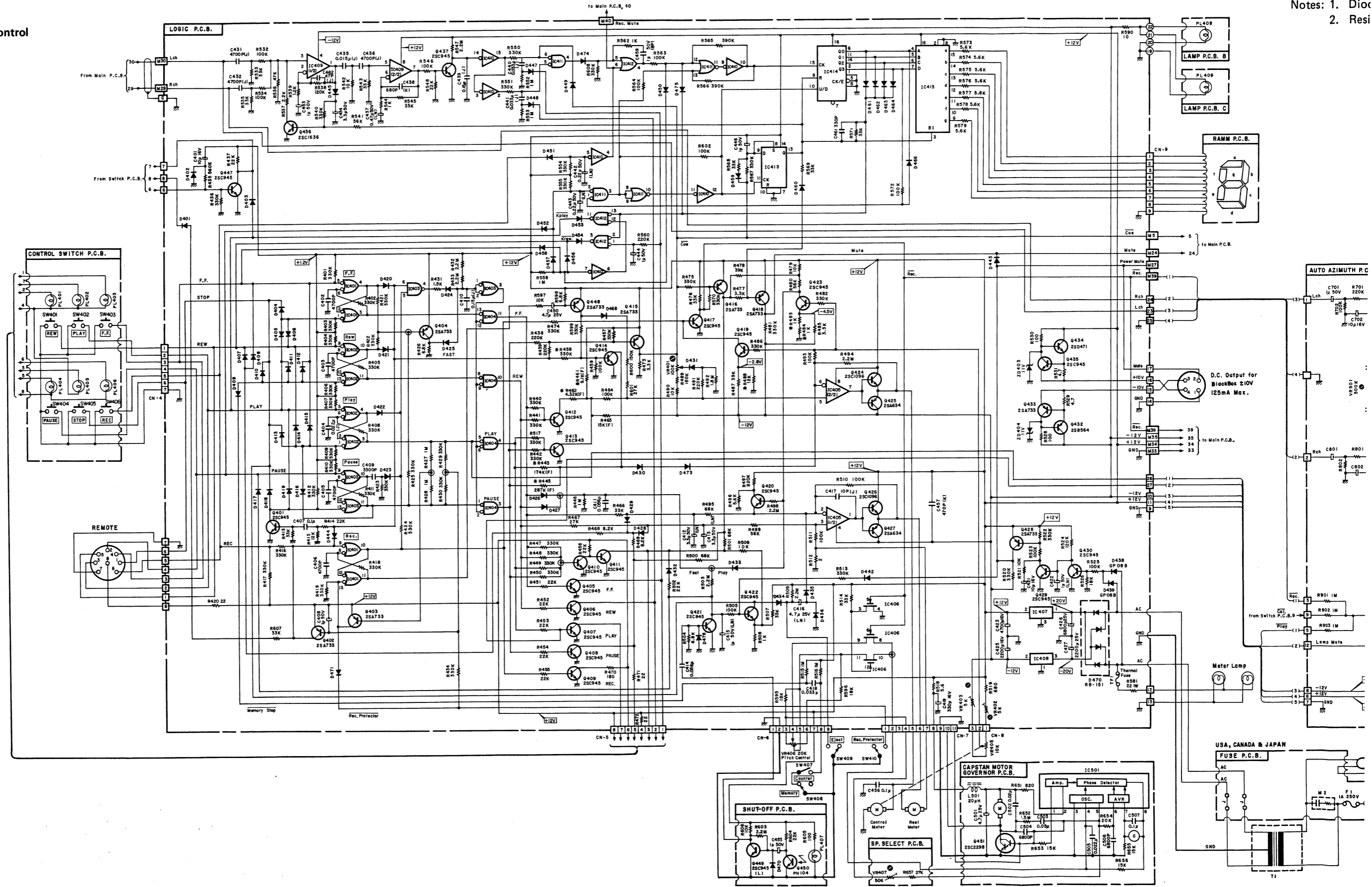

Fig. 13.2

- Notes: 1. Diode is 1SS53, 1S953, or 1S1555 unless otherwise specified.  
 2. Resistor and capacitor marked with \* show typical value.

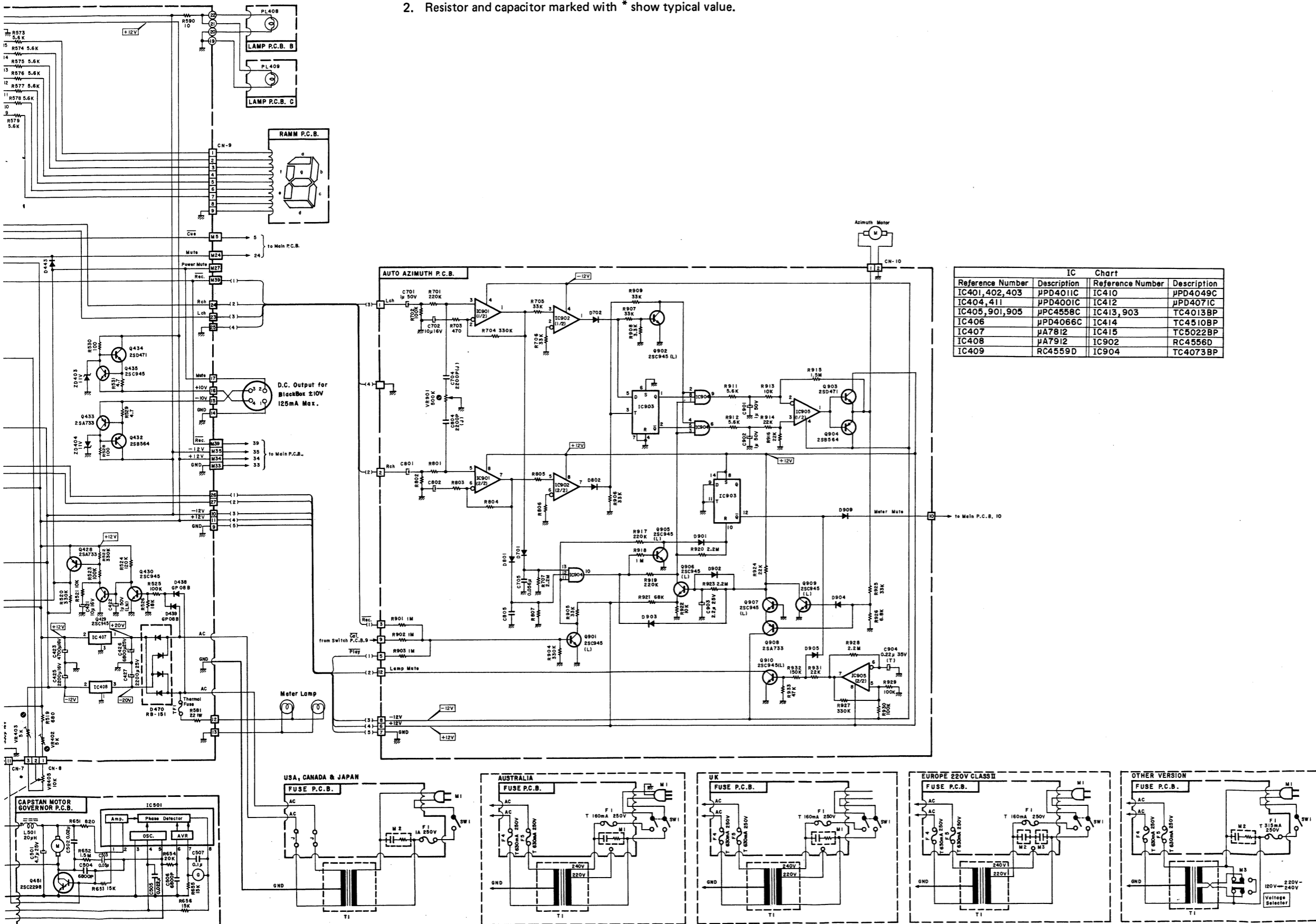

Fig. 13.2

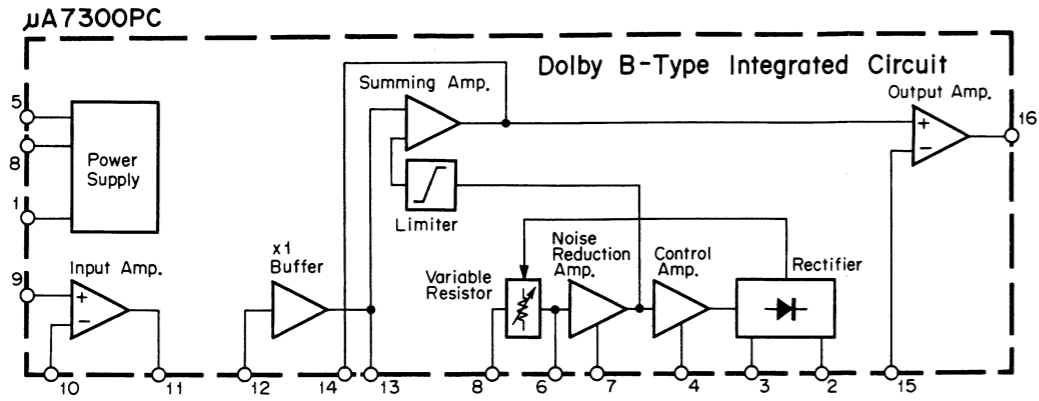

Fig. 13.3 Dolby NR IC  $\mu$ A7300PC

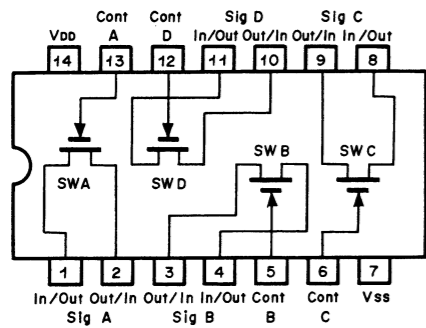

Fig. 13.4 Bilateral Switch C-MOS IC  $\mu$ PD4066C

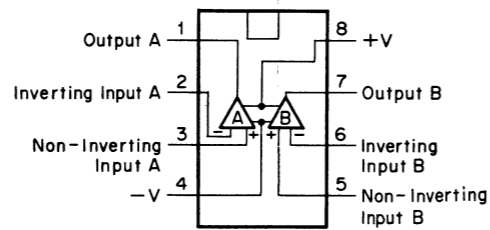

Fig. 13.5 Operational Amp. IC

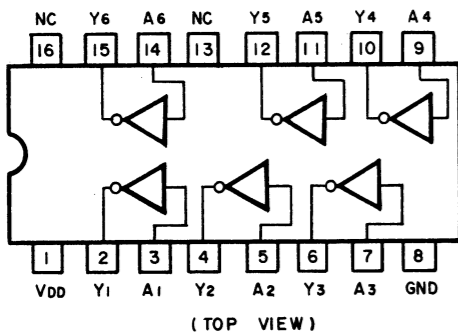

Fig. 13.6 Inverter C-MOS IC  $\mu$ PD4049C

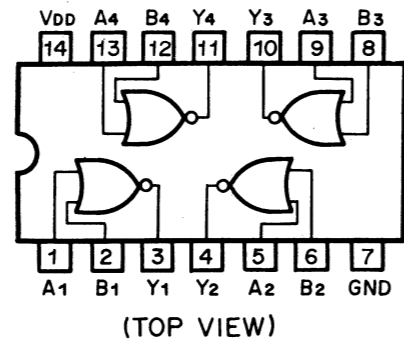

Fig. 13.7 NOR Gate C-MOS IC  $\mu$ PD4001C

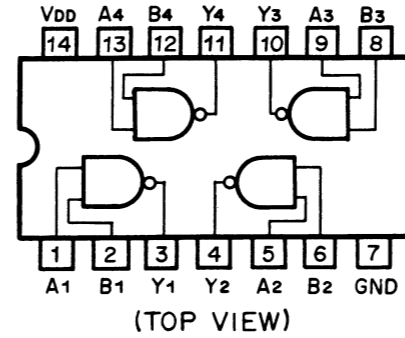

Fig. 13.8 NAND Gate C-MOS IC  $\mu$ PD4011C

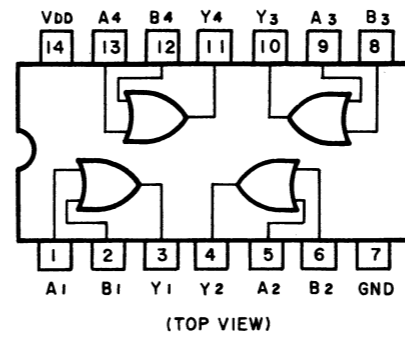

Fig. 13.9 OR Gate C-MOS IC  $\mu$ PD4071C

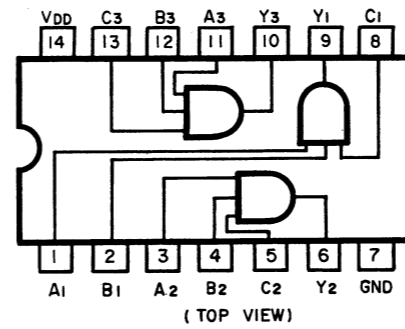

Fig. 13.10 AND Gate C-MOS IC  $\mu$ PD4073C

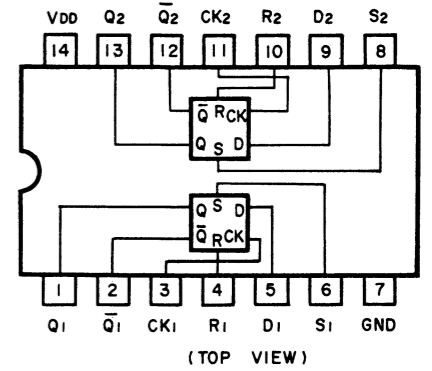

Fig. 13.11 D-Type Flip-Flop C-MOS IC TC4013BP

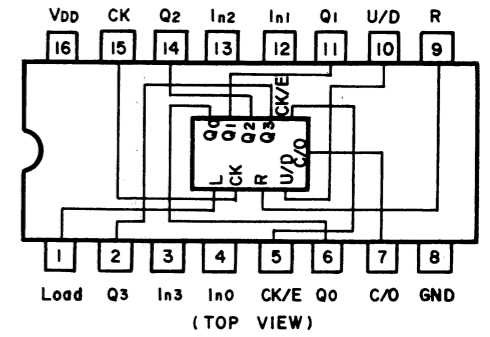

Fig. 13.12 BCD Up/Down Counter C-MOS IC TC4510BP

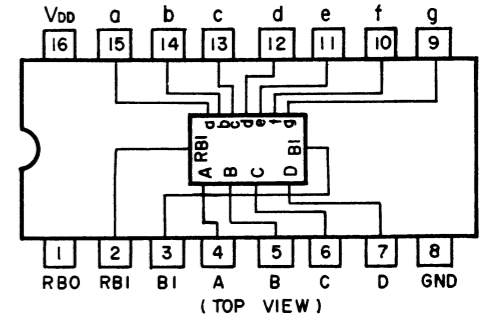

Fig. 13.13 BCD to 7-segment Decoder/Driver C-MOS IC TC5022BP

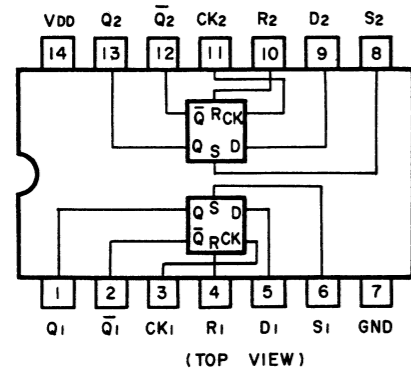

Fig. 13.11 D-Type Flip-Flop C-MOS IC TC4013BP

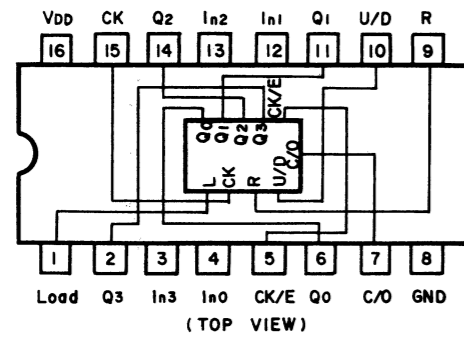

Fig. 13.12 BCD Up/Down Counter C-MOS TC4510BP

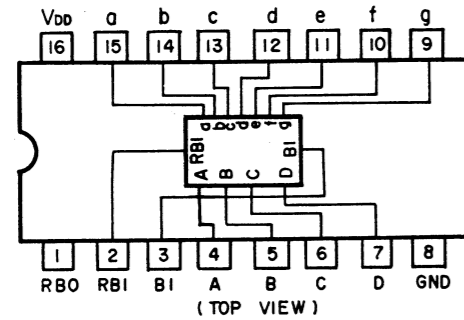

Fig. 13.13 BCD to 7-segment Decoder/Driver C-MOS IC TC5022BP

#### 14. SPECIFICATIONS

Power Source . . . . .	100, 120, 120/220-240, 220 or 240 V; 50/60 Hz (according to country of sale)
Power Consumption . . . . .	27 W max.
Tape Speed . . . . .	1-7/8 ips. (4.8 cm/sec.) ± 0.5%
Frequency Response . . . . .	10-22,000 Hz ± 3 dB (-20 dB rec. level, ZX tape)
Signal-to-Noise Ratio . . . . .	Better than 66 dB (IHF-A WTD RMS, ref. 400 Hz, 3% THD, w/Dolby NR, ZX tape, 70 μsec EQ)
Total Harmonic Distortion . . . . .	Less than 0.8% at 400 Hz, 0 dB w/ZX tape Less than 1.0% at 400 Hz, 0 dB w/SX, EX-II tapes
Wow-and-Flutter . . . . .	Less than 0.08% WTD peak, 0.04% WTD RMS
Erase . . . . .	Better than 60 dB below saturation level at 1 kHz
Separation . . . . .	Better than 37 dB at 1 kHz, 0 dB
Crosstalk . . . . .	Better than 60 dB at 1 kHz, 0 dB
Bias Frequency . . . . .	105 kHz
Input . . . . .	50 mV, 50 k ohms
Output . . . . .	1 V (400 Hz, 0 dB, output control at max.) 2.2 k ohms
Headphone Output . . . . .	45 mW (at 400 Hz, 0 dB, 8 ohms)
DC Output Jack . . . . .	±10 V DC, 125 mA max.
Dimensions . . . . .	482(W) x 143(H) x 340(D) millimeters 19(W) x 5-5/8(H) x 13-3/8(D) inches
Approximate Weight . . . . .	9 kg. 19 lb. 13 oz

- Specifications and appearance design are subject to change for further improvement without notice.
- Dolby NR under license from Dolby Laboratories.
- The word "DOLBY" and the Double-D-Symbol are trademarks of Dolby Laboratories.